



## #J1400, J1401 Installation Instructions 1997-2006 Jeep TJ 4" Suspension Lift

### Read and understand all instructions and warnings prior to installation of product and operation of vehicle.

Zone Offroad Products recommends this system be installed by a professional technician. In addition to these instructions, professional knowledge of disassembly/ reassembly procedures and post installation checks must be known. Minimum tool requirements include the following: Assorted metric and standard wrenches, hammer, hydraulic floor jack and a set of jack stands. See the "Special Tools Required" section for additional tools needed to complete this installation properly and safely.

#### » PRODUCT SAFETY WARNING

Certain Zone Suspension Products are intended to improve off-road performance. Modifying your vehicle for off-road use may result in the vehicle handling differently than a factory equipped vehicle. Extreme care must be used to prevent loss of control or vehicle rollover. Failure to drive your modified vehicle safely may result in serious injury or death. Zone Offroad Products does not recommend the combined use of suspension lifts, body lifts, or other lifting devices.

You should never operate your modified vehicle under the influence of alcohol or drugs. Always drive your modified vehicle at reduced speeds to ensure your ability to control your vehicle under all driving conditions. Always wear your seat belt.

#### » TECHNICAL SUPPORT

*Live Chat* provides instant communication with Zone tech support. Anyone can access live chat through a link on [www.zoneoffroad.com](http://www.zoneoffroad.com).

[www.zoneoffroad.com](http://www.zoneoffroad.com) may have additional information about this product including the latest instructions, videos, photos, etc.

Send an e-mail to [tech@zoneoffroad.com](mailto:tech@zoneoffroad.com) detailing your issue for a quick response.

**888.998.ZONE** Call to speak directly with Zone tech support.

#### » PRE-INSTALLATION NOTES

1. Special literature required: OE Service Manual for model/year of vehicle. Refer to manual for proper disassembly/reassembly procedures of OE and related components.
2. Adhere to recommendations when replacement fasteners, retainers and keepers are called out in the OE manual.
3. Larger rim and tire combinations may increase leverage on suspension, steering, and related components. When selecting combinations larger than OE, consider the additional stress you could be inducing on the OE and related components.
4. Post suspension system vehicles may experience drive line vibrations. Angles may require tuning, slider on shaft may require replacement, shafts may need to be lengthened or trued, and U-joints may need to be replaced.
5. Secure and properly block vehicle prior to installation of Zone Offroad Products. Always wear safety glasses when using power tools.
6. If installation is to be performed without a hoist, Zone Offroad Products recommends rear alterations first.
7. Due to payload options and initial ride height variances, the amount of lift is a base figure. Final ride height dimensions may vary in accordance to original vehicle attitude. Always measure the attitude prior to beginning installation.

#### Difficulty Level

easy 1 2 **3** 4 5 difficult

Estimated installation hours: 5-7

#### Special Tools Required

T40, T50, T55 Torx Sockets

Small Pickle Fork

#### Tire/Wheel Fitment

33" x 12.50" tire/15x8, 3.5" B.S. wheel

## Kit Contents

Qty	Part	Qty	Part
2	Front Coil Spring	1	Bolt Pack - Rear Sway Bar Links
2	Rear Coil Spring	2	Front Sway Bar Link w/Bushings
1	1/8" x 1-1/4" Cotter Pin	2	Sway Bar Link U-Bracket
4	Lower Control Arm	1	Bolt Pack - Front Sway Bar Links
8	3/4"OD x 9/16"ID x 2.620" Sleeve	2	5/8"OD x 0.48"ID x 1.375" Sleeve
16	LCA Bushing	6	5/8"OD x 0.41"ID x 1.375" Sleeve
4	90 Degree Grease Fitting	2	2" Front Bump Stop Extension (Large Diameter)
4	Straight Grease Fitting	1	Bolt Pack - Front Bump Stop
4	Rear UCA Cam Plate	2	2" Rear Bump Stop Extension (Small Diameter)
1	Bolt Pack - Rear UCA	2	10mm x 80mm Bolt - Rear Bump Stop
1	Rear Track Bar Bracket	6	T-Case Drop Spacer
1	Bolt Pack - Rear Track Bar	6	1/2" x 3" Bolt - T-Case Drop (J1400 only)
1	7/8"OD x 9/16"ID x 1.60" Crush Sleeve	6	Conical Washers (J1400 only)
2	Rear Sway Bar Link w/Bushings	6	Bolt Pack - T-Case Drop (J1401 only)
		1	Shift Linkage Bracket
		1	Bolt Pack - Shift Linkage Bracket

### Important—measure before starting!

Measure from the center of the wheel up to the bottom edge of the wheel opening

LF \_\_\_\_\_ RF \_\_\_\_\_

LR \_\_\_\_\_ RR \_\_\_\_\_

## INSTALLATION INSTRUCTIONS

1. Park the vehicle on an appropriate work surface. Ensure that the vehicle is in park for automatic transmission or in first gear for manual transmissions and the parking brake is applied. Block the wheels for added safety.
2. If equipped, remove the forward transmission skid plate. Remove the two frame mount bolts (one per side) and three center skid plate bolts. Remove the skid plate from the vehicle.
3. Locate the new lower control arms (4 total), control arm bushings, control arm sleeves (3/4" OD x 2.620" long) and provided grease fittings **Figure 1**. Apply grease to the bushings/sleeves and install them in each control arm end. Install the grease fitting in the threaded holes located in each control arm end. One straight and one 90 degree fitting will be used for each arm with the straight fitting installed in the short end of the arm (short length after the arm bend). Ensure the 90 degree fitting is pointed toward the body of the control arm.

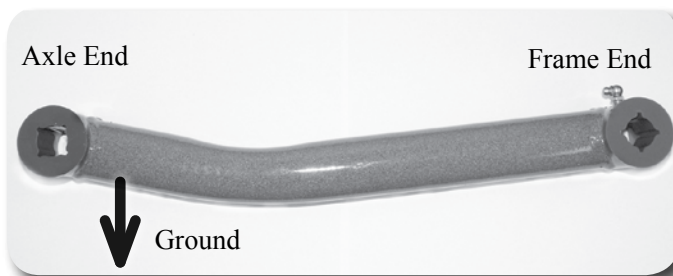

Figure 1

### Step 2 Note

As a result of the increased suspension travel of this system, the auxiliary forward transmission skid plate cannot be reinstalled. Installation of the skid plate will result in contact with the front driveshaft under normal suspension travel, possibly causing damage to the driveshaft.

### Step 4 Note

The track bar bolt may require a T-50 Torx socket on early models.

### » FRONT INSTALLATION

4. Remove the bolt mounting the front track bar to the passenger's side of the axle **Figure 2**. Save track bar bolt and nut tab. Allow the track bar to hang free.

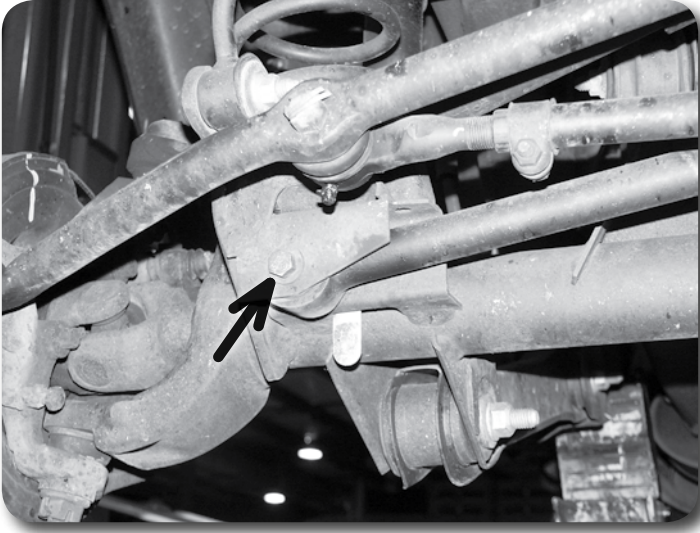

Figure 2

5. Raise the front of vehicle with a hydraulic jack and place jack stands under the frame rails, just behind the lower control arm pockets.
6. Remove the wheels.
7. 1997 model TJ only: Mark the position of the alignment cam adjusters located at the end of each front lower control arm at the axle **Figure 3**.

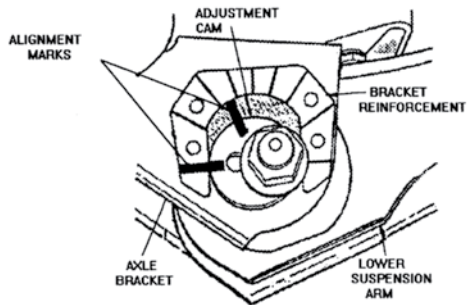

Figure 3

8. Support the front axle with a hydraulic jack. Remove the shocks. Save the lower shock hardware.
9. Remove the upper mounting nut from the sway bar links **Figure 4**. Disconnect the links from the sway bar with a pickle fork to release the tapered seat.
10. Disconnect the sway bar link from the axle. Remove the nut and the sway bar link from the bolt. Some early models will require a T55 torx socket to hold the bolt from rotating. Later models used a bolt with a serrated neck that is pressed into the bracket so it will not rotate. Save axle mount hardware.

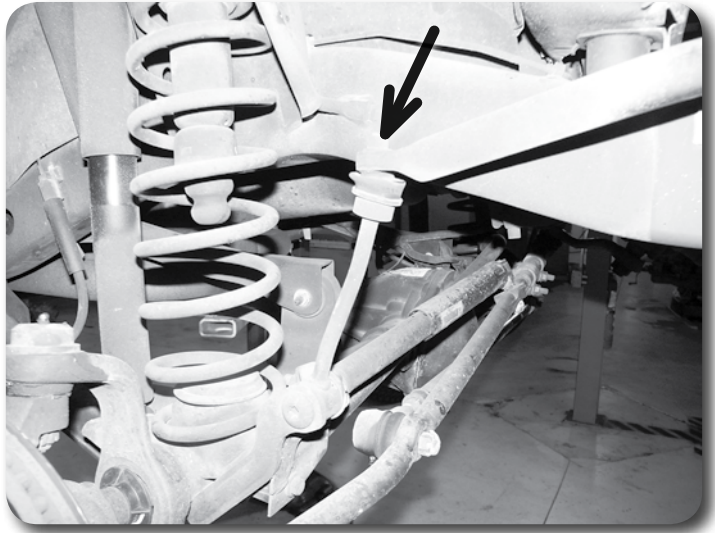

Figure 4

11. Remove the cotter pin and castellated nut from the drag link end at the pitman arm **Figure 5**. Thread the nut back on a couple of turns. Strike the pitman arm near the drag link end to release the tapered seat. Take care not to damage the end. Remove the nut and the drag link from the pitman arm. Save hardware.

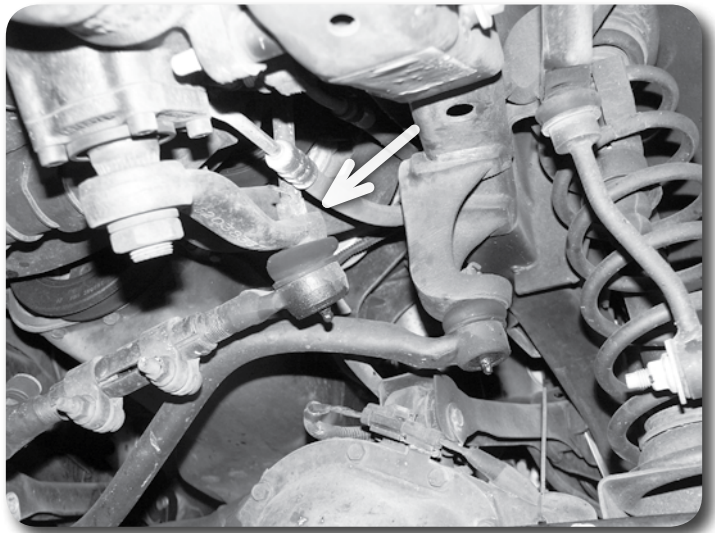

Figure 5

### Step 14 Note

It may be necessary to disconnect the brake line brackets from the frame to allow the axle to lower enough to remove the springs. This will require a T40 torx socket.

### Step 15 Note

Be sure to drill the hole with 5/16" drill bit to ensure that the bolt can cut the threads properly. Self-tapping bolt is located in hardware pack #439.

12. Remove the driver's side coil spring retainer clip located on the back side of the axle coil seat. Save clip and bolt.
13. Ensure that the axle is well supported with a jack. Loosen and remove the driver's and passenger's side lower control arm bolts at the axle and frame. Remove the control arms from the vehicle. Save the control arm hardware.
14. Lower the axle with the jack and remove the original coil springs. Take care not to over extend the brake lines.
15. Locate the center of the coil mount on the axle and drill a 5/16" hole **Figure 6**. Using the provided 3/8" x 1" self-tapping bolt, tap the hole and remove the bolt. A lower bump stop extension will be installed here when the coil spring is installed.

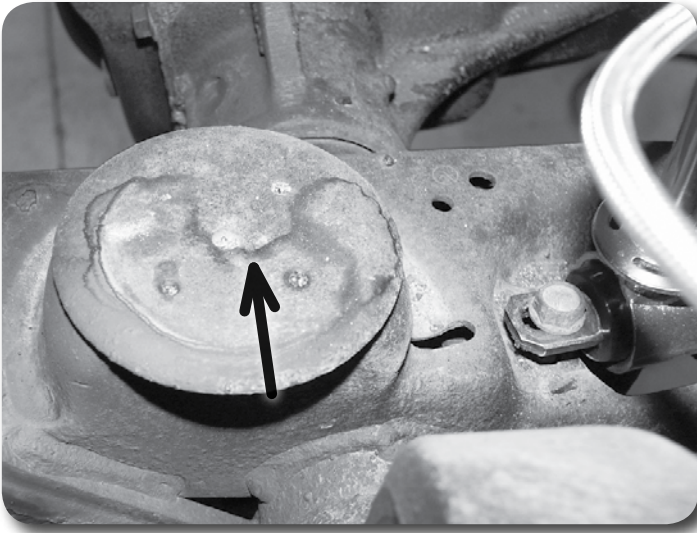

Figure 6

### Step 16 Note

3/8" x 2-1/2" bolts/washers are located in hardware pack #439.

16. Install the provided new front coil springs in the vehicle. When installing the coils, insert a 2" bump stop spacer (large diameter) in the coil before placing it on the axle mount. Fasten the bump stop spacer with a 3/8" x 2-1/2" bolt and washer. Use Loctite on the bolt threads and torque to approximately 25 ft-lbs.
17. Raise the axle until the coils touch the upper mounts. Reinstall the driver's side coil retainer and torque to 20 ft-lbs.
18. Install the new driver's and passenger's side lower control arms with the factory bolts/nuts/washers. Snug the bolts but do not tighten completely. The lower control arm bolts will be tightened with the weight of the vehicle on the suspension.
19. Install the new shocks with the provided upper bushings/hardware. Leave the upper nut loose.
20. Attach the shock to the axle with the original shock hardware. Torque bolts to 20 ft-lbs. Go back and tighten the upper shock stem nut until the stem bushings begin to swell. Install the thin jam nut on the stem and tighten it against the first nut.
21. Locate the factory track bar mount on the passenger's side of the axle. Measure from the center of the original track bar mounting hole 3/4" toward the driver's side and mark. Drill a 13/32" hole at the mark through the front and back faces of the track bar mount **Figure 7**. This will be the new mounting point for the track bar. Do not install the track bar at this time.

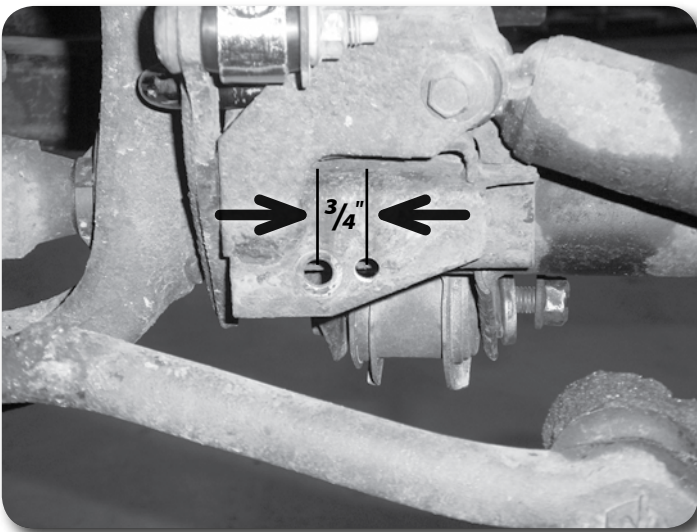

Figure 7

### Step 23 Note

All fasteners needed for the front sway bar link installation are located in the #746 hardware pack.

22. Reattach the drag link to the pitman arm with the original castellated nut. Torque the nut to 60 ft-lbs. Align the cotter pin hole with the slots in the nut and install the new provided cotter pin. Never loosen the nut to align the cotter pin, only tighten.
23. Install the provided sway bar link u-brackets to each end of the sway bar using 10mm x 40mm bolts, nuts and 3/8" USS washers. Install the bolt up through the bracket and sway bar hole. Position the bracket so that the through holes are parallel with the sway bar link axle mount hole. Torque bolt to 40 ft-lbs.
24. Locate the new front sway bar links. The front links have offset eyes. Install a 5/8"OD x 0.480" ID steel sleeve in one end and a 5/8"OD x 0.407ID sleeve in the other end of each link. The links will have the bushings preinstalled.
25. Attached the new sway bar links to the axle mount with the factory hardware and to the new sway bar u-bracket with 3/8" x 2-1/2" bolts, nuts and washers run from inside out. The end with the smaller ID sleeve will mount to the u-bracket. When mounted correctly, the links will taper in toward the center of the vehicle as the run from the axle to the sway bar **Figure 8**. Torque the factory hardware to 55 ft-lbs and 3/8" hardware to 30 ft-lbs.

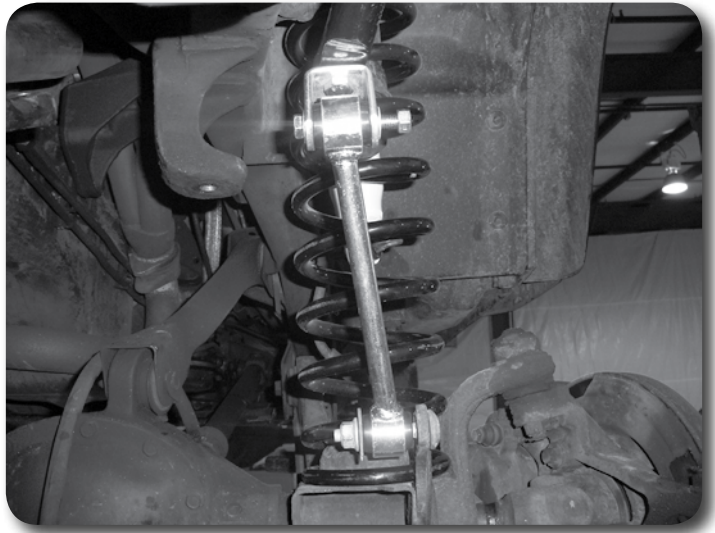

Figure 8

26. Install the wheels and torque the lug nuts to the manufacturer's specs. See vehicle owner's manual.
27. Remove the jack stands and lower the vehicle to the ground.
28. Bounce the front of the vehicle to settle the suspension.
29. Connect the front track bar to the newly drilled hole in the axle mount with the original hardware. Torque bolt to 50 ft-lbs. Note: To aid in aligning the track bar hole have an assistant turn the steering wheel to shift the trackbar in the correct direction.
30. Torque the lower control arm bolts to 105 ft-lbs. Note: If working on a 97 model, be sure to align the marks made at the beginning of the installation before tightening the bolts and torque O.E. cam bolt to 85 ft-lbs..
31. Check all hardware for proper torque.

## » REAR INSTALLATION

1. Disconnect the rear track bar from the passenger's side frame mount **Figure 9**. Save hardware.



Figure 9

2. Raise the rear of vehicle with a hydraulic jack and place jack stands under the frame rails, just ahead of the lower control arm pockets.
3. Remove the wheels.
4. Support the rear axle with a hydraulic jack. Remove the shocks. Save all shock hardware.
5. Disconnect the sway bar links from the sway bar and frame **Figure 10**. Save hardware.

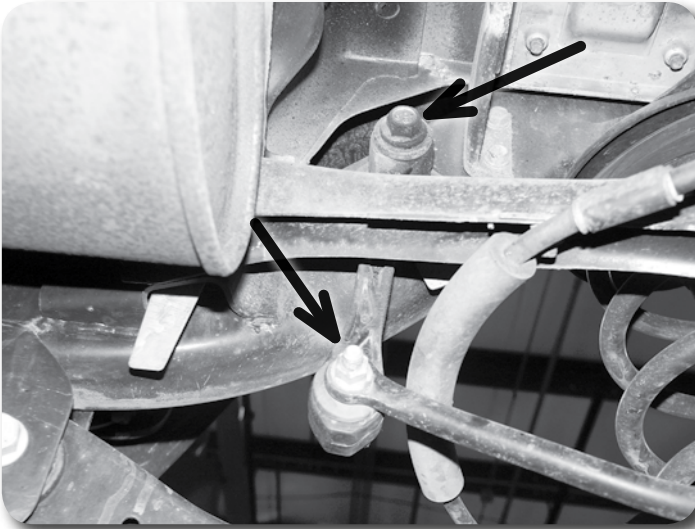

Figure 10

6. Lower the axle with the hydraulic jack and remove the coil springs.
7. Remove the passenger's side upper control arm bolt at the axle. Place one of the provided offset cam washers between the two tabs located on the axle mount on each side of the original control arm hole. Position the washer so that the hole is closer toward the front of the vehicle and even (up and down) with the existing hole. Mark the perimeter of the hole using the washer as a guide. Remove the

### Step 7 Note

A rotary grinding tool is best suited for this step but not necessary. A drill and appropriate sized bits will work as well.

washer. Notice that the hole marking is located in a factory perforated section of the mount. Using a rotary grinding tool, remove the perforated section of the mount where the mark was made. Repeat this on the other side of the mount.

Figure 11

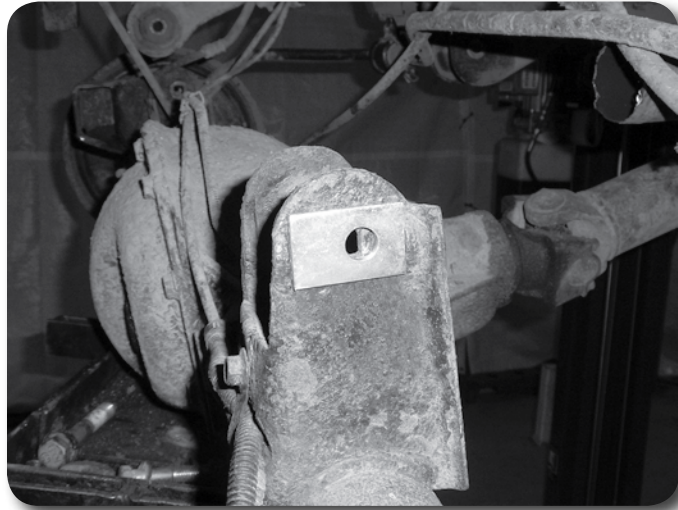

Figure 11

### Step 8 Note

10mm class 10.9 hardware is located in the #738 hardware pack.

### Step 13 Note

A small amount of grease on the bump stop will make installation easier.

8. Loosely attach the passenger's side upper control arm to the modified mount with the provided 10mm x 80mm bolts, nuts, and washers along with the two cam washers. The cams will be set in the appropriate position after the driver's side mount has been modified.
9. Remove the driver's side upper control arm bolt at the axle and repeat the modification that was done to the passenger's side.
10. With both upper mounts modified, snug the upper control arm hardware so that the cams are offset toward the front of the vehicle and position flat against the mount, between the tabs. The upper control arm bolts will set to the correct torque with the weight of the vehicle on the suspension.
11. With the axle well supported, remove the factory lower control arms from the axle and frame mounts. Install the new control arms with the factory hardware. Install the arms so that the short end (past the bend) is mounted to the axle. Leave hardware loose.
12. Remove the factory bump stop from the upper coil mount. Large pliers can be used to pull it out. Remove the factory bump stop retainer cup by removing the bolt from the center.
13. Install the provided 2" bump stop spacer between the factory retainer cup and the frame with a 10mm x 80mm bolt. Torque the bolt to 30 ft-lbs. Reinstall the factory rubber bump stop in the retainer.
14. Remove the plastic cover from the track bar mount on the driver's side of the axle [Figure 12](#). Discard the cover.





Figure 12

15. Disconnect the track bar from the axle by removing the Torx head bolt (T55). Note how the track bar is positioned in the vehicle. It can rest in the vehicle or be removed for reinstallation later.
16. Position the supplied track bar relocation bracket on the original track bar axle mount **Figure 13**. Install the provided 1.600" long crush sleeve in the original track bar mount point. Install a provided 12mm x 80mm bolt and 7/16" washer through the supplied bracket, factory mount, sleeve and out through the other side of the mount. Loosely fasten with the factory nut tab. If the factory is damaged, use a provided 12mm nut.

### Step 16 Note

All fasteners needed for the rear track bar bracket installation are located in the #711 hardware pack.



Figure 13

17. With the new bracket in place, drill out the remaining four holes using the bracket as a template. The lowest hole is 3/8" while the rest are 5/16". Fasten the bracket with the supplied 3/8" x 1" bolt, nut and washers in the lower hole and 5/16" x 1" bolts, nut and washers in the remaining holes. Torque the 3/8" bolt to 30 ft-lbs and the 5/16" to 22 ft-lbs. Go back and torque the 12mm main bolt to 60 ft-lbs.
18. Install the factory track bar in the new bracket with the provided 12mm x 80mm bolt, nut and 7/16" washers. The bolt must be installed from back to front. Leave the bolt loose.

## Step 24 Note

All fasteners needed for the rear sway bar link installation are located in the #709 hardware pack.

19. Install the new coil springs in the upper and lower spring seats. Note: The coils have identical ends so they mount in either direction.
20. Lightly grease and install the provided hourglass bushing and steel sleeve in the rear shock eyes. Note: One end will have a bar pin preinstalled.
21. Attach the new shocks to the frame with the original hardware. Torque bolts to 20 ft-lbs.
22. Raise the rear axle until the shocks can be fastened to the axle mounts with the original hardware. Torque bolts to 55 ft-lbs.
23. Locate the new rear sway bar links with preinstalled bushings. Install the provided 5/8" OD x 0.407ID steel sleeves in each link end.
24. Install the rear sway bar links to the original frame mounts and the sway bar with new 10mm x 60mm bolts, nuts and washers. Torque bolts to 30 ft-lbs. The factory 10mm nut tabs can be reused at the frame mounts.
25. Install the wheels and torque the lug nuts to the manufacturer's specs. See vehicle owner's manual.
26. Remove the jack stands and lower the vehicle to the ground. Note: Make sure the track bar doesn't get pinched when lowering the vehicle.
27. Bounce the rear of the vehicle to settle the suspension. Torque the lower control arm bolts to 105 ft-lbs. Torque the upper control arm bolts at the axle to 55 ft-lbs.
28. Reattach the rear track bar to the passenger's side frame mount with the original hardware. Have an assistant push on the side of the body to help align the track bar in the bracket. Torque frame and axle bolts to 70 ft-lbs.
29. Check all hardware for proper torque.

## »» TRANSFER CASE DROP INSTALLATION

1. Locate and loosen the 4 nuts mounting the transmission mount to the transfer case skid plate. Do not completely remove the nuts.
2. Support the transfer case skid plate with a hydraulic floor jack.
3. Loose but do not remove all six skid plate mounting bolts.
4. Remove the three passenger's side bolts and slowly lower the skid plate from the frame. Lower the skid plate just enough to install the provided spacers between the frame and the skid plate.
5. Attach the skid plate to the frame (through the new spacers) with the provided hardware: 97-02 models (kit #J1300) use 1/2" x 2" bolts with the provided conical washers. 03-05 models (kit #J1301) use 12mm x 50mm bolts with 7/16" USS washers **Figure 14**. Leave hardware loose.

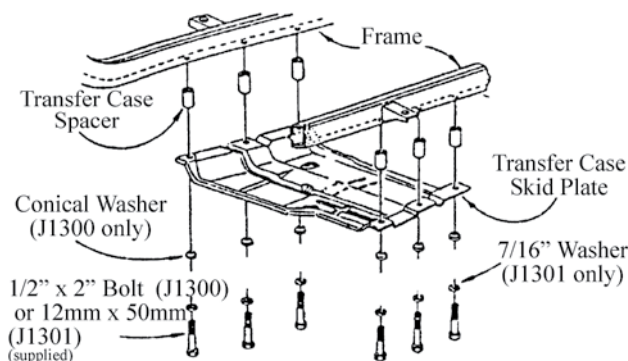

Figure 14

6. Repeat the procedure on the driver's side.
7. With all the spacers/bolts installed, torque bolts to 65 ft-lbs.
8. Torque the 4 transmission mount nuts to 18 ft-lbs.
9. Locate the transfer case shift linkage pivot bracket mounted to the underside of the floor on the driver's side, next to the transfer case. The bracket is mounted to the floor with four bolts that are accessed under the carpet in front of the driver's seat. Pull the carpet up and remove the bolts **Figure 15**. Save hardware.

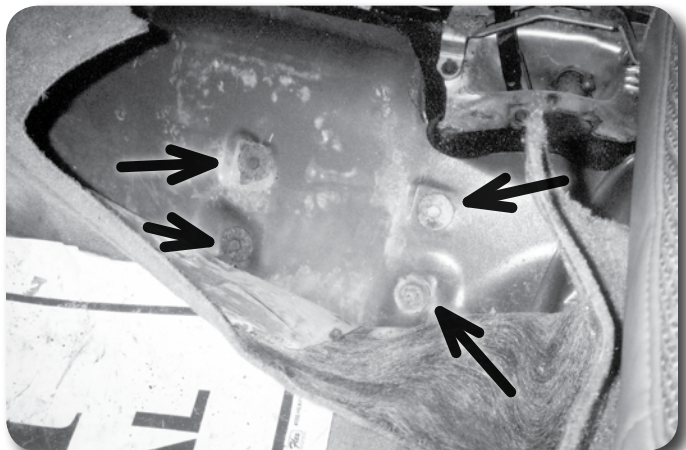

Figure 15

10. Working underneath the vehicle, slide the pivot bracket down and off of the pivot rod running from the transfer case. Remove the bracket assembly from the vehicle.
11. Remove the two bolts that fasten the pivot bushing plate to the bracket. Remove the bushing plate and gasket (when equipped). Save hardware.
12. Attach the provided pivot bushing relocation bracket to the factory bracket with the original hardware. The studs in the new bracket should point out away from the main factory bracket. Torque bolts to 10 ft-lbs.
13. Attach the pivot bushing plate and gasket (when equipped) to the studs on the new plate with the provided 1/4" nuts and washers. Torque nuts to 10 ft-lbs.
14. Install the modified pivot bracket assembly in the vehicle by sliding the linkage rod into the relocated pivot bushing. Reattach the bracket to the floor with the original hardware **Figure 16**. Torque nuts to 15 ft-lbs.

### Step 13 Note

All fasteners needed for the pivot bracket installation are located in the #704 hardware pack.



Figure 15

15. Check transfer case shift operation to see that all positions engage completely. Adjust the shift linkage as necessary. The linkage adjustment is located near the pivot bracket.

---

## » **POST-INSTALLATION**

1. A front end alignment is required to adjust toe-in setting as well as straighten the steering wheel. Caster can be adjusted on 97 models using the factory alignment cams bolts. Zone Suspension offers replacement cam bolt kits for all 97-06 models, part #J5311.
2. Check all hardware for proper torque after 500 miles. Check hardware at regularly scheduled maintenance intervals.
3. Adjust headlights.

### **Post-Installation Warnings**

1. Check all fasteners for proper torque. Check to ensure for adequate clearance between all rotating, mobile, fixed, and heated members. Verify clearance between exhaust and brake lines, fuel lines, fuel tank, floor boards and wiring harness. Check steering gear for clearance. Test and inspect brake system.
2. Perform steering sweep to ensure front brake hoses have adequate slack and do not contact any rotating, mobile or heated members. Inspect rear brake hoses at full extension for adequate slack. Failure to perform hose check/ replacement may result in component failure.
3. Perform head light check and adjustment.
4. Re-torque all fasteners after 500 miles. Always inspect fasteners and components during routine servicing.