



# Installation Instructions

PARTS INCLUDED	QTY	PARTS INCLUDED	QTY
Winch	1	Roller Fairlead	1
Solenoid Box	1	Clevis Hook	1
Hardware Bag	1	Remote Control	1

## SAFETY PRECAUTIONS

**Warning!** Observe safety precautions for personal safety and the safety of others. Improper equipment operation may cause personal injury and equipment damage.

Read the following carefully before attempting to operate your winch and keep the instructions for future reference.

### 1. Dress Properly:

- Don't wear loose clothing or jewelry. They can be caught in moving parts.
- Wear leather gloves when handling winch cable. Do not handle cable with bare hands as broken wires can cause injuries.
- Non-skid footwear is recommended.
- Protective hair covering to contain long hair.

### 2. Keep a Safe Distance:

- Ensure that all persons stand well clear of winch cable and load during winch operation, 1.5 times the cable length recommended. If a cable pulls loose or breaks under load it can lash back and cause serious personal injury or death.
- Don't step over the cable.
- All visitors and onlookers should be kept away from the work area.
- Keep proper footing and balance at all times.

### 3. Don't Abuse the Cord:

- Never carry your winch by the cord or yank it to disconnect it from the receptacle.
- Keep cord from heat, oil and sharp edges.

### 4. Don't Overwork the winch:

- If the motor becomes uncomfortably hot to touch, stop and let it cool for a few minutes.
- Don't maintain power to the winch if the motor stalls.
- Don't exceed maximum line pull ratings shown in tables. Shock loads must not exceed these ratings.

### 5. Avoid Unintentional Starting:

- Winch clutch should be disengaged when not in use and fully engaged when in use.

### 6. Check Damaged Parts:

- Before using, you should check your winch carefully. Any part that is damaged should be properly repaired or replaced by an authorized service centre.

### 7. Repair Your Winch:

- When repairing, use only identical replacement parts or it may cause considerable danger to the user.

### 8. Re-spool the cable:

- Leather gloves must be worn while re-spooling. To re-spool correctly, it is necessary to keep a slight load on the cable. Hold the cable with one hand and the remote control switch with the other. Start as far back and in the centre as you can. Walk up keeping load on the cable as the winch is powered in.
- Do not allow the cable to slip through your hand and do not approach the winch too closely.
- Turn off the winch and repeat the procedure until all the cable except 1m is left.
- Disconnect the remote control switch and finish spooling in cable by rotating the drum by hand with clutch disengaged.
- On hidden winches, spool in cable under power but keep hands clear.



## Installation Instructions

**Warning:** The use of any other accessory or attachment other than those recommended in the Fitting Instructions may present a risk of personal injury.

### WINCH OPERATION WARNINGS

Read the following carefully before attempting to operate your winch and keep the instructions for future reference.

1. The uneven spooling of cable, while pulling a load, is not a problem, unless there is a cable pile up on one end of the drum. If this happens reverse the winch to relieve the load and move your anchor point further to the centre of the vehicle. After the job is done, you can un-spool and rewind for a neat lay of the cable.
2. Store the remote control switch inside your vehicle where it will not become damaged, inspect it before you plug it in.
3. When ready to begin spooling in, plug in remote control switch with clutch disengaged, do not engage clutch with motor running.
4. Never connect the hook back to the cable. This causes cable damage. Always use a sling or chain of suitable strength.
5. Observe your winch while winching, if possible while standing at a safe distance. Stop the winching process every meter or so to assure the cable is not piling up in one corner. Jamming the cable can break your winch.
6. Do not attach tow hooks to winch mounting apparatus. They must be attached to vehicle frame.
7. The use of a snatch block will aid recovery operations by providing a doubling of the winch capacity and a halving of the winching speed, and the means to maintain a direct line pull to the centre of the rollers. When double loading during stationary winching, the winch hook should be attached to the chassis of the vehicle.
8. Ensure rated "D" or bow shackles are used in conjunction with an approved tree trunk protector to provide a safe anchor point.
9. When extending winch cable, ensure that at least FIVE (5) wraps of cable remain on drum at all times. Failure to do this could result in the cable parting from the drum under load. Serious personal injury or property damage may result.
10. All winches are provided with a Red Cable marking to identify that 5 cable wraps remain on the winch drum when this mark appears at the rollers. No recovery should be attempted beyond this marking.
11. Since the greatest pulling power is achieved on the innermost layer of your winch, it is desirable to pull off as much line as you can for heavy pulls (you must leave 5 wraps minimum on the drum-red cable). If this is not practical use a snatch block and double line arrangement.
12. Draping a heavy blanket or similar object over the extended winch cable is recommended as it will dampen any back lash should a failure occur.
13. Neat, tight spooling avoids cable blinding, which is caused when a load is applied and the cable is pinched between the others. If this happens, alternatively power the winch in and out. Do not attempt to work a bound cable under load, free by hand.
14. Apply blocks to wheels when vehicles are on an incline.
15. Battery:
  - Be sure that the battery is in good condition. Avoid contact with battery acid or other containments.
  - Always wear eye protection when working around a battery.
  - Have the engine running when using the winch, to avoid flattening the battery.
16. Winch cable:
  - Be sure that the cable is in good condition and is attached properly.
  - Do not use the winch if cable is frayed.
  - Do not move the vehicle to pull a load.



## Installation Instructions

- Do not replace the cable with a cable of lesser strength.
  - The life of cable is directly related to the use and care it receives. Following its first and subsequent uses, a cable must be wound onto the drum under a load of at least 500lbs (230kg) or the outer wraps will draw into the inner wraps and severely damage the cable during winching. The first winch use should be a familiar run while in a relaxed, non-recovery situation. Spool out the cable until the red cable mark appears (about five wraps on the drum), when rewind the cable onto the drum under a load of 500lbs (230kg) or more. This will slightly tension and stretch the new cable and create a tight cable wrap around the drum. Failure to do so may result in cable damage and reduced cable life.
  - When the cable is replaced, be sure to apply locktite, or the cable clamp thread. Tighten the clamp screw properly but do not over-tighten. The locktite will prevent loosening of the screw in arduous conditions. Locktite 7471 primer and 222 Thread Locker are recommended.
17. Do not attempt to exceed the pulling limits of this winch.
  18. Do not drive your vehicle to assist the winch in any way. Vehicle movement in combination with winch operation may overload the cable, the winch itself or cause damaging shock loads.
  19. Shock loads when winching are dangerous! A shock load occurs when an increased force is suddenly applied to the cable. A vehicle rolling back on a slack cable may induce a damaging shock load.
  20. The winches shown in this manual are solely for vehicle and boat mount, non-industrial applications.
  21. Do not use winch in hoisting applications due to required hoist safety factors and features.
  22. Do not use the winch to lift, support or otherwise transport personnel.
  23. Do not move your winch by lifting the cable leads or the clutch handle lever.



## Installation Instructions

### INSTALLATION

#### MOUNTING YOUR WINCH

- 1 a) The winch is to be mounted into a suitable steel mounting frame using the 4 point foot mounting system in either a horizontal or vertical plane.
  - b) It is very important that the winch be mounted on a flat surface so that the three sections (motor, cable drum and gear housing) are properly aligned.
  - c) Before commencing installation, ensure the mounting facility being used is capable of withstanding the rated capacity of the winch.
  - d) The fitment of winches and / or a frontal protection system may affect the triggering of SRS air bags. Check that the mounting system has been tested and approved for winch fitment in the air bag equipped vehicle.
2. Smittybilt manufactures winch mounting frames and / or Frontal Protection Systems to suit most popular vehicles. Winch frames are packaged with detailed instructions.
  3. Should you wish to manufacture your own mounting plate the dimensions below will assist. A steel mount plate of 6mm thickness is recommended. Fasteners should be steel high tensile grade 5 or better. A poorly designed mount may void warranty.
  4. The winch should be secured to the mounting with 3/8" UNC\* 1-1/4" steel bolts and spring washers provided.
  5. The roller fairlead is to be mounted so as to guide the rope onto the drum evenly.

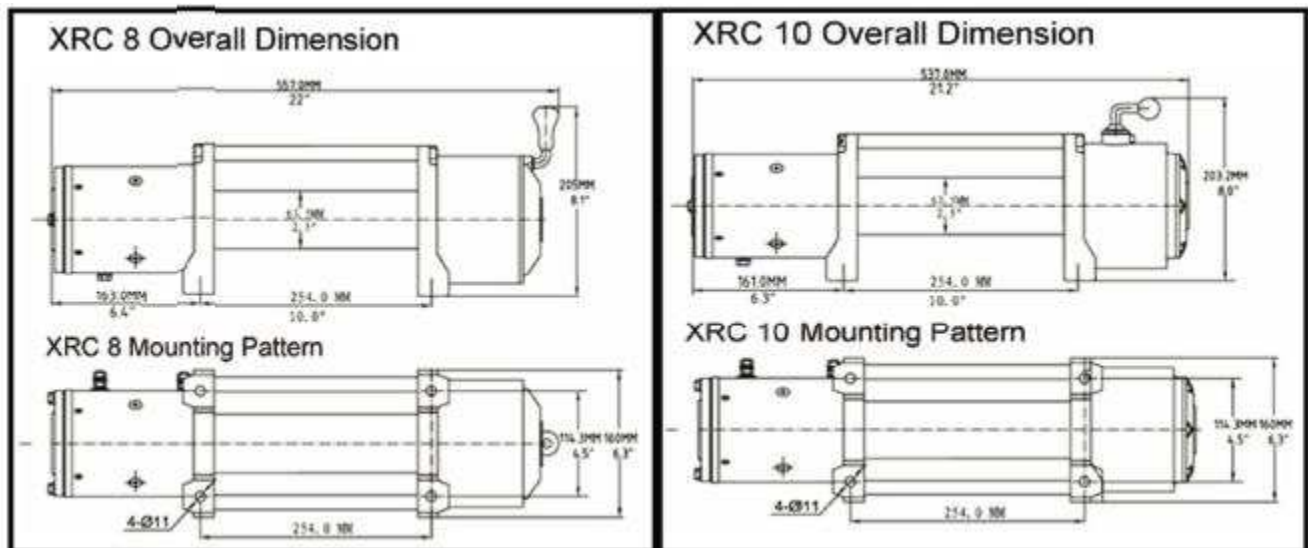

#### LUBRICATION INSTALLATION

All moving parts in the winch are permanently lubricated with high temperature lithium grease at the time of assembly. Under normal conditions factory lubrication will suffice. Lubricate cable periodically using light penetrating oil. Inspect for broken strands and replace if necessary. If the cable becomes worn or damaged, it must be replaced.

#### CABLE INSTALLATION

Unwind the new cable by rolling it along the ground, to prevent kinking. Remove old cable and observe the manner in which it is attached to the drum flange.

For Technical Support/Warranty Information please call 310-762-9944  
Smittybilt, 400 West Artesia Blvd, Compton, CA 90220



# Installation Instructions

## ELETRICAL CONNECTION

For normal self-recovery work, your existing electrical system is adequate. A fully charged battery and proper connections are essential. Run the vehicle engine during winching operations to keep charged.

**Pay close attention to proper electrical cable connection as follows (refer to Diagram 1)**

Be sure to observe the following steps for a correct and safe electrical connection:

1. Short Red cable (B') connecting to the red terminal (B) of winch motor.
2. Short black cable with yellow jacket (C') connecting to the yellow terminal (C) of the motor.
3. Short black cable with black jacket (D') connecting to the black terminal (D) of the motor.
4. Thin black cable (A') connecting to bottom terminal (A) of the motor.
5. Long black cable (1.8m), one terminal (a) connecting to the bottom terminal (A) of the motor, and the other terminal negative (-) connecting to negative (-) terminal of battery.
6. Long red cable positive (+) connecting to positive (+) of battery.

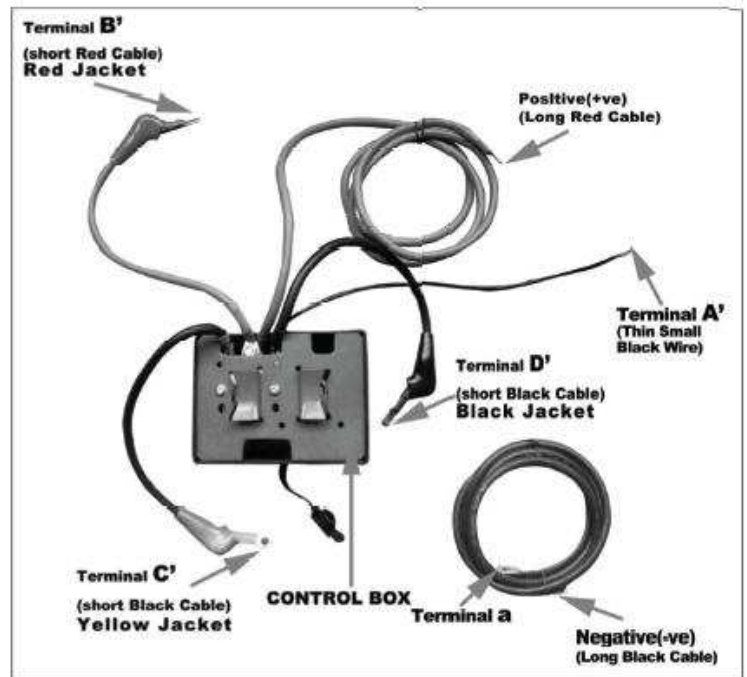
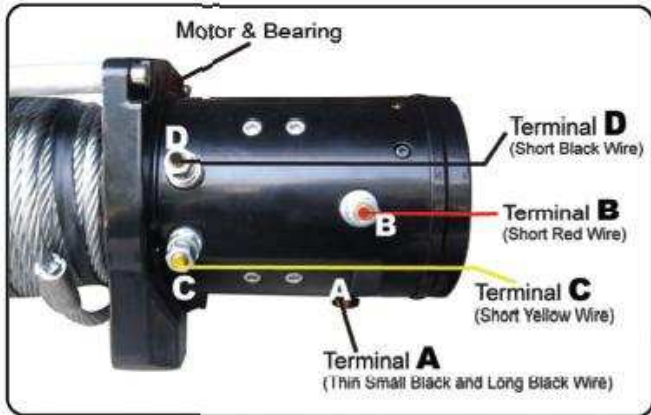



# Installation Instructions

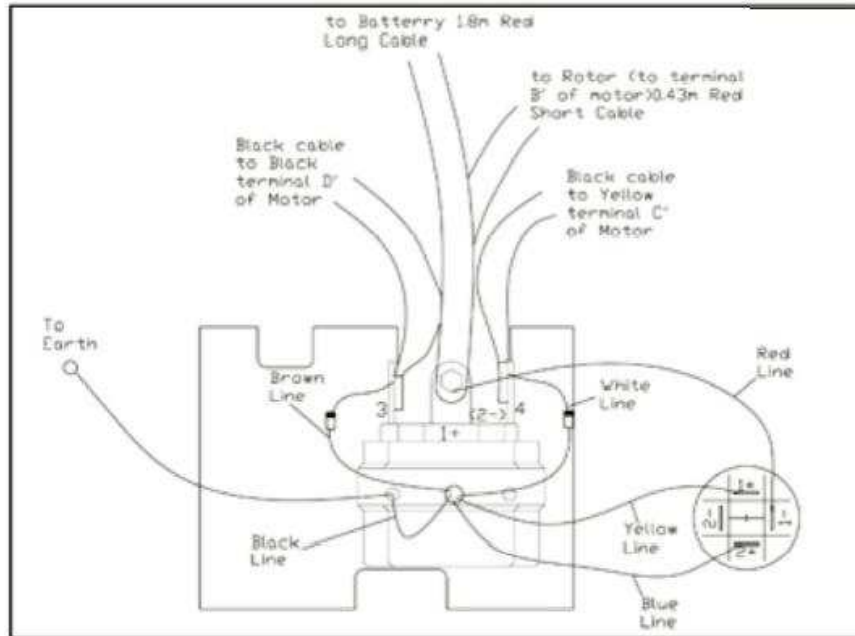

## NOTE:

1. Your battery must be kept in good condition.
2. Be sure battery cables are not drawn taught across any surfaces, which could possibly damage them.
3. Corrosion on electrical connections will reduce performance or may cause a short.
4. Clean all connections especially in remote control switch and receptacle.
5. In salty environments use a silicone sealer to protect from corrosion.
6. Index the heads of the plate studs into the keyhole slots on the back of the winch.
7. Attached the winch/Adaptor plate assembly to your trailer hitch, by inserting the trailer hitch ball through the shaped hole in the Adaptor plate.

## WINCH OPERATION

**SUGGESTION:** The best way to get acquainted with how your winch operates is to make a few test runs before you actually need to use it. Plan your test in advance. Remember you can hear your winch as well as you can see it operate. Get to recognize the sound of a light steady pull, a heavy pull, and sounds caused by load jerking or shifting. Soon you will gain confidence in operating your winch and its use will become second nature to you.

### OPERATING:

1. Ensure the vehicle is secured by applying the parking brake or chocking the wheels.
2. Pull out the winch cable the desired length and connect to an anchor point. The winch clutch allows rapid uncoiling of the cable for hooking onto the load or anchor point. The shifter tab located on the gear housing of the winch operates the clutch as follows:
  - a) To disengage the clutch, move the clutch shifter tab to the "OUT" position. Cable may be free spooled off the drum.
  - b) To engage the clutch, move the clutch shifter tab into the "IN" position. The winch is now ready for pulling.
3. Recheck all cable rigging before proceeding.



## Installation Instructions

4. Plug in the winch hand control. It is recommended that the winching operation takes place from the driver's position to ensure safe operation.
5. To commence winching operation, start vehicle engine, select in transmission, maintain engine speed at idle.
6. Operate the remote control switch to IN or OUT until the vehicle has been retrieved. Regularly check the winch to ensure cable is winding onto the drum evenly.

### Note:

1. Never winch with your vehicle in gear or in park, which would damage your vehicle's transmission.
2. Never wrap the cable around the object and hook onto the cable itself, this can cause damage to the object being pulled, and kink or fray the cable.
3. Keep hands, clothing, hair and jewelry clear of the drum area and cable when winching.
4. Never use the winch if the cable is frayed, kinked or damaged.
5. Never allow anyone to stand near the cable, or in line with the cable behind the winch while it is under power, if the cable should slip or brake, it can suddenly whip back towards the winch, causing a hazard for anyone in the area. Always stand well to the side while winding.
6. Don't leave the switch plugged in when winch is not in use.

**CHECK THE WINCH CAREFULLY AND THOROUGHLY BEFORE OPERATING!**

## MAINTENANCE

It is highly recommended that the winch be used regularly (once a month). Simply power the cable out 15m, free spool 5m and then power back in. This will keep all components in good working condition so that the winch can be relied on when needed. Contact your authorized outlet for technical assistance and repairs.

SPARE PARTS: A comprehensive range of spare parts is available. For further information please contact Smittybilt Automotive Products.

### NOTE:

**The safety precautions and instructions discussed in this manual can't cover all possible conditions and situations that may occur. It must be understood by the operator that common sense and caution are factors, which cannot be built into this product, but must be applied by the operator.**



# Installation Instructions

## **XRC 8 Specifications**

Rated Line Pull: 8000Lbs (3600kgs) single-line  
 Motor: 5.5hp /12V, Series Wound  
 Control: Remote Switch, 12' (3.7m) lead  
 Gear Train: 3-Stage Planetary  
 Gear Ratio: 172.8:1  
 Clutch: Rotating Ring Gear  
 Brake: Automatic In-The-Drum  
 Drum Size: (Diameter x Length) 2.5" x 8.82" (63.5mm x 224mm)  
 Wire Rope: (Diameter x Length) 21/64" x 94' (8.2mm x 28.5m)  
 Fairlead: 4-Way Roller  
 Remote Control: Included  
 Recommended Battery: 650CCA Minimum for Winching  
 Battery Leads: 25mm<sup>2</sup> , 72" (1.8m)  
 Finish: Black  
 Weight: 94.0lbs (42.5Kgs)  
 Mounting Bolt Pattern: 10.0" x 4.50"

### **Line speed and amp draw (first layer)**

Line Pull	Lbs	NO LOAD	2000	4000	6000	8000
	Kgs		910	1814	2720	3630
Line Speed	Fpm	37.2	18	13.1	10.2	8.2
	Mpm	11.4	5.5	4.1	3.2	2.6
Motor Current	Amps	75	195	260	335	410

### **Line pull and cable capacity**

Layer of cable		1	2	3	4
Rated line pull per layer	Lbs	8000	6900	5850	5100
	Kgs	3630	3130	2650	2310
Cable capacity per layer	Ft	16	42	72	94
	Mpm	5	12	21	28





# Installation Instructions

## XRC 8 WINCH PARTS LIST

No.	Parts No.	Description	Qty	No.	Part No.	Description	Qty
1	97281-01	Sun Gear-Input	1	24	97281-24	Spring Washer	10
2	97281-02	Gear Carrier-Input	1	25	97281-25	Gear Box Base	1
3	97281-03	Gear Carrier-Intermediate	1	26	97281-26	Gasket	1
4	97281-04	Washer-1.2mm thickness	2	27	97281-27	Inner Gear	1
5	97281-05	Gear Carrier-Output	1	28	97281-28	Clutch Gear	1
6	97281-06	Outer Spline	1	29	97281-29	Gear Box Tube	1
8	97281-08	Drum	1	30	97281-30	Gasket	1
10	97281-10	Brake System	1	32	97281-32	Gear Box End Cover	1
11	97281-11	Coupling Joint	1	36	97281-36	Bearing	1
12	97281-12	Rotor	1	39	97281-39	Clutch Lever	1
16	97281-16	Motor End Cover	1	41	97281-41	Wire Rope	1
17	97281-17	Carbon Frame & Brush Assy	1	45	97281-45	Winch Mount Bolt	1
18	97281-18	Stator	1	46	97281-46	Clevis Hook	4
19	97281-19	Tie Rod Bolt	1	47	97281-47	Roller Fairlead	1
20	97281-20	Motor Base	4	49	97281-49	Control Box	1
21	97281-21	Nylon Bearing	1	50	97281-50	Remote Control	1
22	97281-22	Tie Rod	2		97281		1

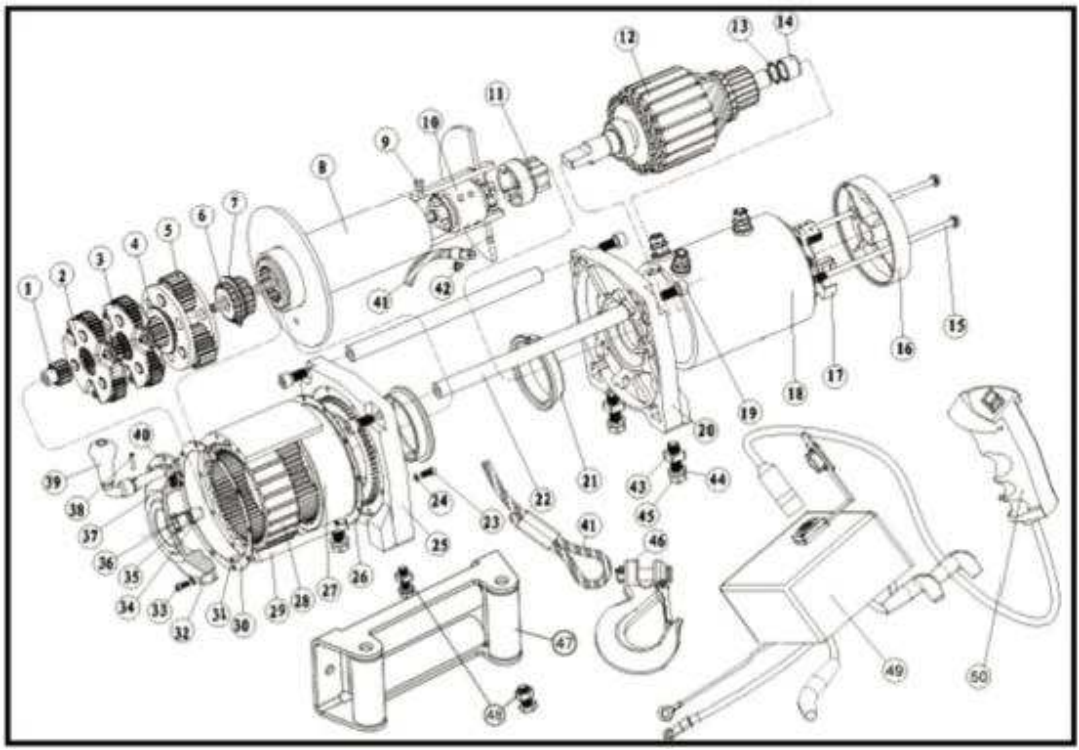

For Technical Support/Warranty Information please call 310-762-9944  
 Smittybilt, 400 West Artesia Blvd, Compton, CA 90220  
 Page 10 of 17



# Installation Instructions

## **XRC 10 Specifications**

Rated Line Pull: 1000Lbs (4535kgs) single-line  
 Motor: 5.5hp/12V, Series Wound  
 Control: Remote Switch, 12' (3.7m) lead  
 Gear Train: 3-Stage Planetary  
 Gear Ratio: 218:1  
 Clutch: Rotating Ring Gear  
 Brake: Automatic In-The-Drum  
 Drum Size: (Diameter x Length) 2.5" x 8.82" (63.5mm x 224mm)  
 Wire Rope: (Diameter x Length) 23/64" x 94' (9.2mm x 28.5m)  
 Fairlead: 4-Way Roller  
 Remote Control: Included  
 Recommended Battery: 650CCA Minimum for Winching  
 Battery Leads: 25mm<sup>2</sup>, 72" (1.8m)  
 Finish: Black  
 Weight: 99.0lbs (42.5Kgs)  
 Mounting Bolt Pattern: 10.0" x 4.50"

### **Line speed and amp draw (first layer)**

Line Pull	Lbs	NO LOAD	2000	4000	6000	8000	10000
	Kgs		907	1814	2721	3628	4535
Line Speed	Fpm	29.53	14.44	12.14	10.17	8.86	7.38
	Mpm	9	4.4	3.7	3.1	2.7	2.25
Motor Current	Amps	70	170	240	310	380	425

### **Line pull and cable capacity**

Layer of cable		1	2	3	4
Rated line pull per layer	Lbs	10000	8633	7716	7089
	Kgs	4535	3915	3499	3215
Cable capacity per layer	Ft	16	42	72	94
	Mpm	4.88	12.8	21.95	28.5



# Installation Instructions

## XRC 10 WINCH PARTS LIST

No.	Parts No.	Description	Qty	No.	Part No.	Description	Qty
1	97210-01	Gear Box End Cover	1	17	97281-24	Remote Control	1
2	97281-02	Gasket	1	18	97210-25	Control Box Assy	1
3	97210-03	Sun Gear-Input	1	19	97210-26	Nylon Bearing	2
4	97210-04	Inner Gear	1	20	97210-27	Tie Rod	2
5	97210-05	Gasket	1	21	97210-28	Drum	1
6	97210-06	Outer Spline	2	22	97210-29	Brake System	1
7	97210-07	Gear Carrier-Input	1	23		Coupling Joint	1
8	97210-08	Gear Carrier-Intermediate	1	24	97210-30	Winch Mount Bolt	4
9	97210-09	Washer-1.2mm thickness	2	25	97210-32	Motor Base	1
10	97210-10	Clutch Gear	1	26	97210-36	Rotor	1
11	97210-11	Gear Carrier-Output	1	27	97210-39	Stator	1
12	97210-12	Gear Box Tube	1	28	97210-41	Carbon Frame & Brush Assy	1
13	97210-13	Clutch Handle Assy	1	29	97210-45	Motor End Cover	1
14	97210-14	Outer Spline	1	30	97210-46	Roller Fairlead	4
15	97210-15	Link Screw	4	31	97210-47	Clevis Hook	1
16	97210-16	Gear Box Base	1	32	97210-49	Wire Rope	1

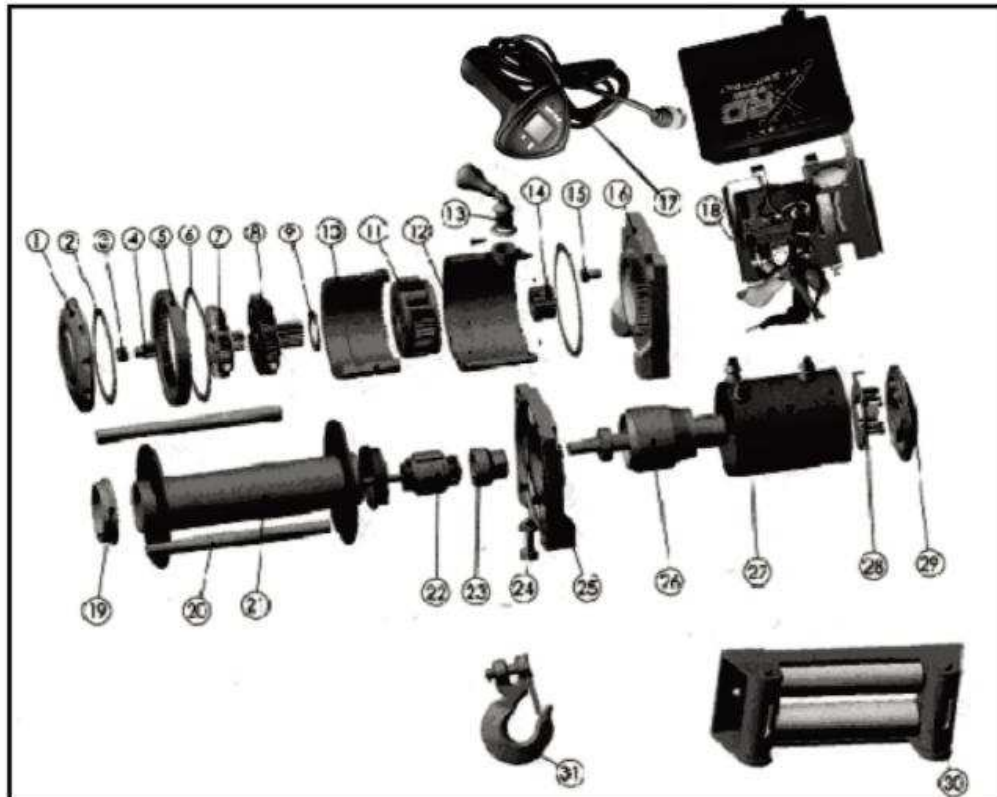



# Installation Instructions

## **XRC 12 Specification**

Rated Line Pull: 12000Lbs (5440kgs) single-line  
 Motor: 6.6hp/12V, Series Wound  
 Control: Remote Switch, 12' (3.7m) lead  
 Gear Train: 3-Stage Planetary  
 Gear Ratio: 265:1  
 Clutch: Rotating Ring Gear  
 Brake: Automatic In-The-Drum  
 Drum Size: (Diameter x Length) 2.5" x 8.82" (63.5mm x 224mm)  
 Wire Rope: (Diameter x Length) 23/64" x 94' (9.2mm x 28.5m)  
 Fairlead: 4-Way Roller  
 Remote Control: Included  
 Recommended Battery: 650CCA Minimum for Winching  
 Battery Leads: 25mm<sup>2</sup>, 72" (1.8m)  
 Finish: Black  
 Weight: 99.0lbs (45.0Kgs)  
 Mounting Bolt Pattern: 10.0" x 4.50"

### **Line speed and amp draw (first layer)**

Line Pull	Lbs	NO LOAD	2000	4000	6000	8000	10000	12000
	Kgs		907	1814	2722	3629	4532	5440
Line Speed	Fpm	23.5	12.8	10.5	9.4	7.4	6.3	5
	Mpm	7.2	3.9	3.2	2.9	2.3	1.9	1.5
Motor Current	Amps	65	120	165	215	270	320	370

### **Line pull and cable capacity**

Layer of cable		1	2	3	4
Rated line pull per layer	Lbs	120000	10270	9200	8500
	Kgs	5440	4654	4169	3852
Cable capacity per layer	Ft	16	42	72	94
	Mpm	5	12	21	28



# Installation Instructions

## **XRC 12 WINCH PARTS LIST**

No.	Parts No.	Description	Qty	No.	Part No.	Description	Qty
1	97212-01	Washer	2	26	97212-26	Gear Box Tube	1
2	97212-02	Sun Gear-Input	1	27	97212-27	Inner Gear	1
3	97212-03	Gear Carrie-Input	1	28	97212-28	Inner Gear	1
4	97212-04	Gear Carrier-Intermediate	1	29	97212-29	Gasket 9500	3
5	97212-05	Washer-1.2mm thickness	2	30	97212-30	Gear Box End Cover	1
6	97212-06	Gear Carrier-Output	1	31	97212-31	Bolt	10
7	97212-07	Outer Spline	1	32	97212-32	Brand	1
8	97212-08	Spline Positioning Ring	1	33	97212-33	Shaft Sleeve	1
9	97212-09	Drum	1	34	97212-34	Clutch Spring	1
10	97212-10	Motor Long Bolt	1	35	97212-35	Washer	1
11	97212-11	Brake Assy	1	36	97212-36	Washer	1
12	97212-12	Coupling Joint	1	37	97212-37	Clutch Steel Ball	1
13	97212-13	Rotor	1	38	97212-38	Connection of Clutch Handle	1
14	97212-14	Washer	2	39	97212-39	Bolt	1
15	97212-15	Long Bolt	2	40	97212-40	Wire Rope	1
16	97212-16	Motor End Cover	1	41	97212-41	Mount Nut	4
17	97212-17	Carbon Assy	1	42	97212-42	Lock Washer	4
18	97212-18	Stator	1	43	97212-43	Mounting Bolt	4
19	97212-19	Link Srew	4	44	97212-44	Clevis Hook	1
20	97212-20	Motor Base	1	45	97212-45	Roller Fairlead	1
21	97212-21	Nylon Bearing	2	46	97212-46	Fairlead Mount Nut	1
22	97212-22	Tie Bar	2	47	97212-47	Fairlead Mount Bolt	2
23	97212-23	Bolt	9	48	97212-48	Control Box Assy	2
24	97212-24	Lock Washer	19	49	97212-49	Handle Remote Control	1
25	97212-25	Gear Box Base	1				1



# Installation Instructions

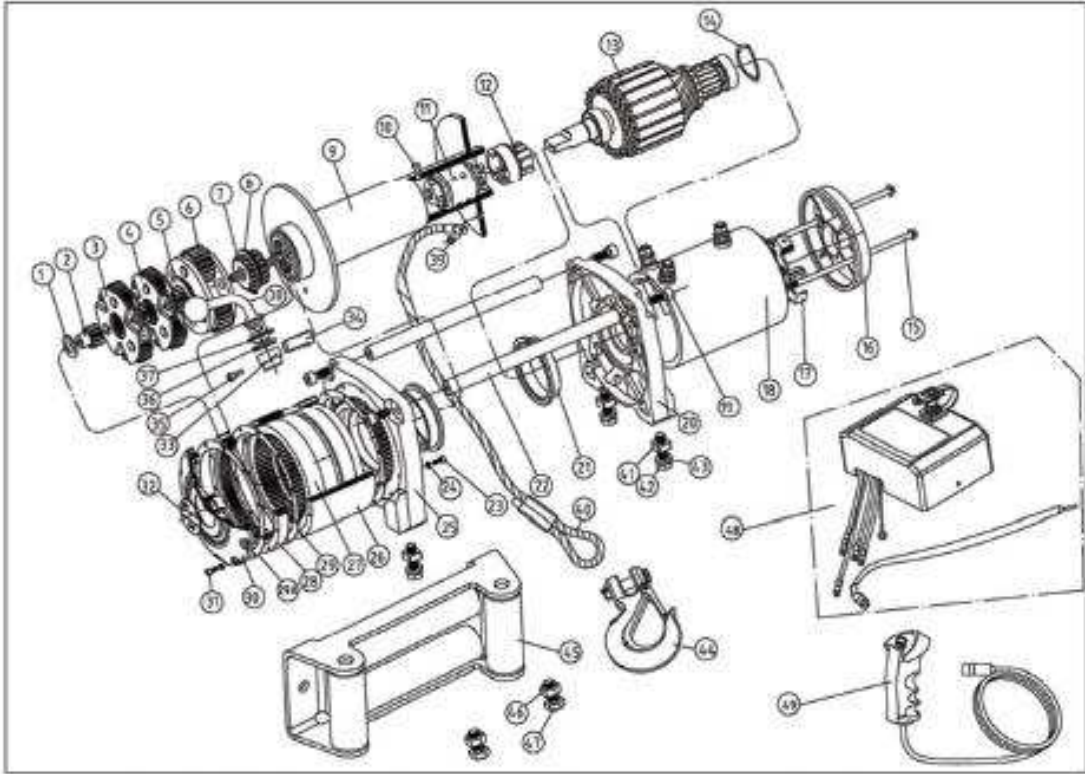



# Installation Instructions

## Troubleshooting

SYMPTOM	POSSIBLE CAUSE	SUGGESTED REMEDY
Motor does not turn on	Switch Assy not connected properly Loose battery cable Solenoid malfunctioning Defective Switch Assembly Defective Motor Water has entered motor	Insert Switch Assy firmly to the connector. Tighten units on cable connectors  Tap solenoid to free contact, applying 12 volts to coil terminal directly.  Makes an audible clicking when activating. Replace Switch Assy  Check for voltage at armature port with switch pressed. If voltage is present, replace motor. Drain and dry. Run in short bursts without load until completely dry.
Motor runs too hot	Long period of operation	Let winch cool down periodically.
Motor runs slowly or without normal power	Battery runs down Insufficient current or voltage	Recharge battery by running vehicle's engine. Clean, tighten or replace the connector.
Motor runs but cable drum does not turn	Clutch not engaged	Ensure lever is completely in "engaged" position. If that does not work, contact qualified technician to check and repair.
Motor runs in one direction only	Defective or stuck solenoid Defective Switch Assy	Tap solenoid to free contacts. Repair or replace solenoid, Replace Switch Assy



## Installation Instructions

### Warranty Limited 2 Year Warranty

Smittybilt, Inc. offers a limited two (2) year warranty (to the original retail purchaser) from each new Smittybilt consumer/RV electric winch against manufacturing defects in workmanship and materials on all the mechanical components.

Electrical components consisting of motors, solenoids, wiring, wire connectors and associated parts have a limited one (1) year warranty.

New cable assemblies are warranted against defects in workmanship and materials when received by the retail purchaser. There is no applicable warranty after initial use.

Warranty registration cards for each winch must be submitted at the time of purchase or within 30 days by the end user. Warranty will only be valid for the original purchaser of the winch and installed on the vehicle for which it was originally registered.

Smittybilt electric winches are intended for recreational self-recovery usage. The warranty is void if the winch is used in commercial/industrial applications.

The obligation under this warranty, statutory or otherwise, is limited to the replacement or repair at the manufacturer's factory, or at a point designated by the manufacturers, of such part(s) as shall appear to the manufacturer, upon inspection of such part(s) as shall appear to the manufacturer, upon inspection of such part(s), to have been defective in material or workmanship. This warranty does not obligate Smittybilt, Inc. to bear the cost of labor or transportation charges in connection with the replacement or repair of defective parts, nor shall it apply to a product upon which repairs or alterations have been made, unless authorized by the manufacturer, or for equipment misused, neglected or improperly installed.

#### IMPORTANT NOTICE

To the fullest extent permitted by applicable law, the following are hereby excluded and disclaimed:

- 1) All warranties of fitness for a particular purpose;
- 2) All warranties of merchantability;
- 3) All claims for consequential or incidental damages.

There are no warranties that extend beyond the description that appears on the face hereof.

Some states do not allow the above exclusions or disclaimers in consumer transactions and as such this disclaimer/exclusion may not apply to you.

To the extent such warranties of fitness or merchantability are deemed to apply to this product, they exist for only so long as the express limited warranty elsewhere set forth is in existence.

Smittybilt, Inc. reserves the right to change, alter or improve its products in design, materials or appearance without incurring any obligation to incorporate such changes in products that were previously manufactured.

This Warranty gives you specific legal rights and you may have other legal rights, which vary from state to state. To submit a warranty claim contact:

**Smittybilt**                      **1-8888-717-5795**  
**400 West Artesia Blvd**  
**Compton, CA 90220**

For Technical Support/Warranty Information please call 310-762-9944  
Smittybilt, 400 West Artesia Blvd, Compton, CA 90220





## Installation Instructions

---

---

### Warranty Information Card

First name:

Last name:

Age:

Sex:

Marital Status:

Level of Education:

City/Province:

Zip/Postal Code:

Country:

Telephone Number:

Email Address:

Which Smittybilt winch did you purchase?

Model Number:

Date of Purchase:

Where did you purchase this product?

Store or catalog name:

Store Location:

How satisfied were you with the dealer and/or sales staff?

Who installed or will install your Smittybilt product?

Is this the first time you have purchase a winch?

If no, what brand have you brought before?

What type of vehicle will this Smittybilt winch be installed on?

Year:

Make:

Model:

2WD:

4WD:

What is the vehicles main use?

What other accessories have you purchased for your vehicle?