

LoadLIFTER5000

Kit No. 57237



www.airliftcompany.com

MN-391
(04608)
ECR 5594

Please read these instructions completely before proceeding with installation

CAUTION - THE AIR LINE MUST BE INSERTED INTO THE AIR FITTING OR THE AIR FITTING MUST BE COVERED BEFORE DRILLING HOLES TO PREVENT ANY DEBRIS OR METAL SHAVINGS FROM CONTAMINATING THE AIR FITTING

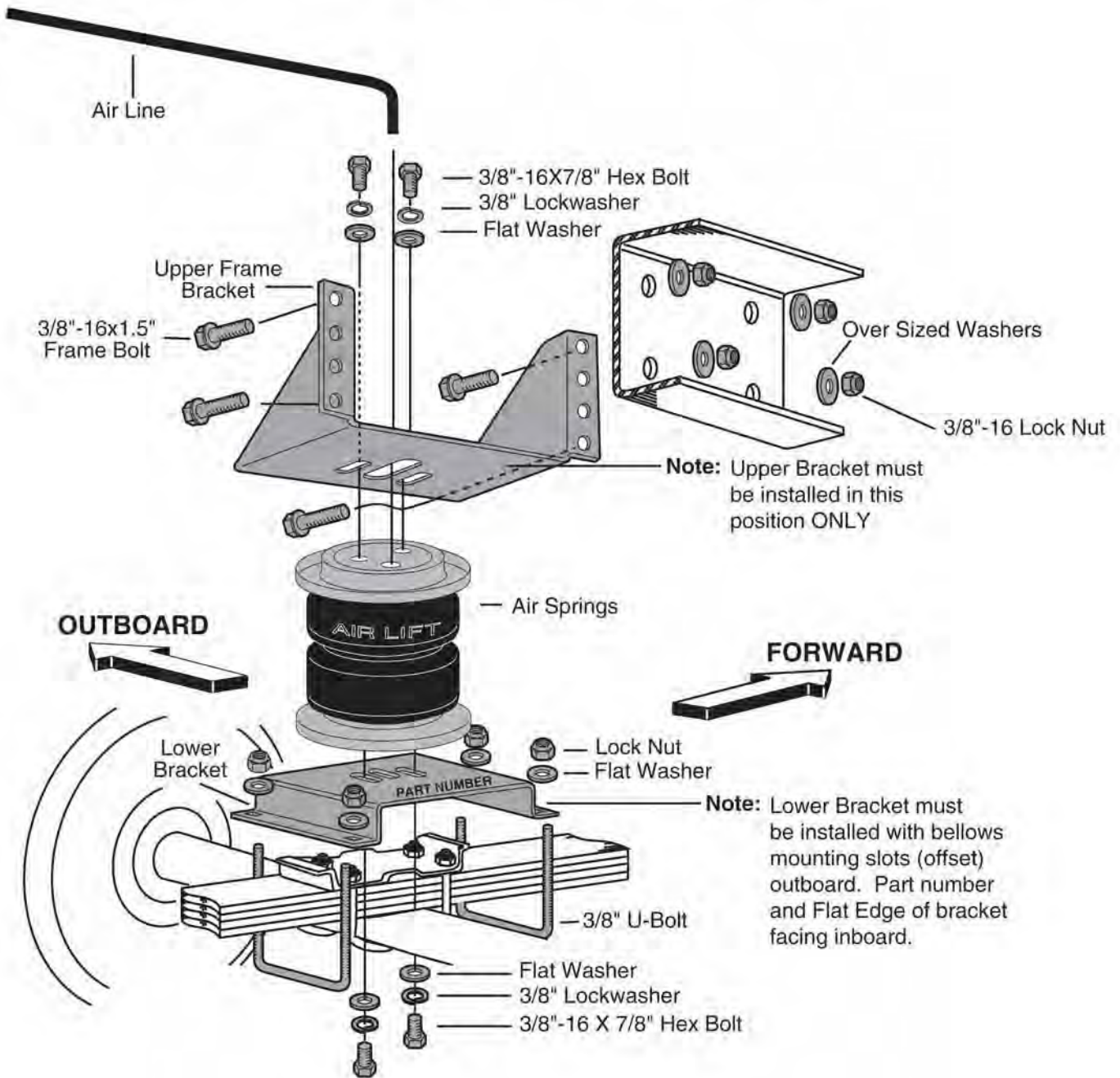

Figure 1

Hardware List

				<u>Air Line Assembly Parts</u>			
Item	Part No.	Description	Quantity	Item	Part No.	Description	Quantity
A	03102	Lower Bracket	2	AA	20086	Air Line Assembly	1
B	07130	Upper Bracket	2	BB	10466	Tie Strap	6
C	58437	2B6 Extended Bellows	2	CC	21230	Valve Caps	2
D	11951	Roll Plate	4	DD	18405	5/16" Flat Washer	2
E	10583	4.5" U-Bolt	4	EE	21234	Rubber Washer	2
F	17159	3/8" x 1.5" WHFB	8	FF	18411	Small Star Washer	2
G	18435	Nyloc Nut	16	GG	21233	5/16" Hex Nut	4
H	18444	3/8" Flat Washer	24				
I	18447	3/8" Large Flat Washer	8				
J	21837	Swivel Head Elbow	2				
K	17203	3/8" x 7/8" HHCS	8				
L	18427	3/8" Lock Washer	8				

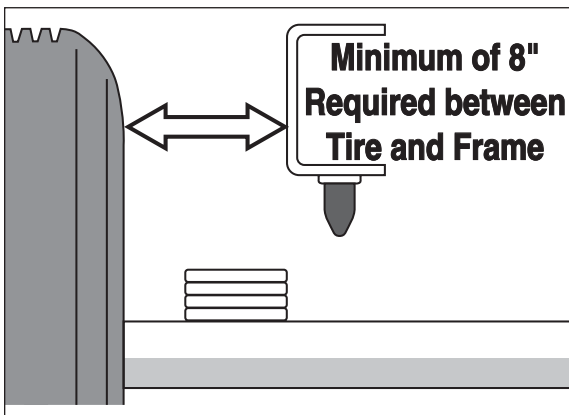

Figure 2

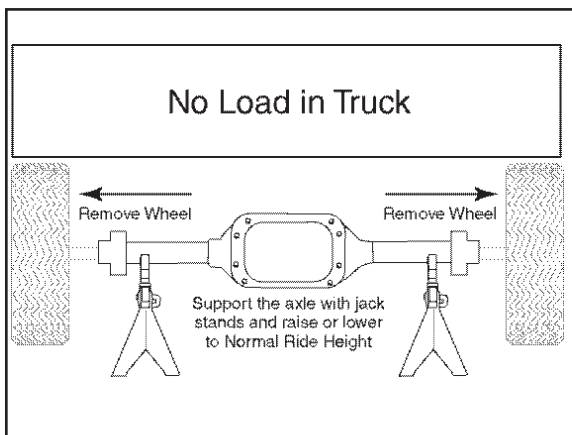

Figure 3

I. Getting Started

1. Raise the vehicle, remove the wheels, and obtain normal ride height (Figures 2 and 3).

NORMAL RIDE HEIGHT: Normal ride height (no load) is defined as the distance between the bottom edge of the wheel-well to the center point of the hub with the vehicle in an “as delivered condition” (without a load, i.e. tool box, camper, etc.). Measurements should be taken before beginning the installation. The distance from the bottom edge of the wheel well to the center point of the hub should be recorded. All Air Lift kits are designed to be installed and operated at normal ride height.

II. Attaching the Upper Bracket

1. Set a roll plate on both ends of the air spring. The radiused (rounded) edge of the roll plate will be towards the air spring so that the air spring is seated in both roll plates (Figures 1,4 and 5).
2. Align the holes in the roll plate with the holes in the air spring and loosely attach the upper bracket with the “legs up” using two 3/8”-16x7/8” bolts, lock washers, and flat washers (Figure 4). The upper bracket must be installed in this position.

III. Attaching the Lower Bracket

1. Make sure that the holes in the air spring, roll plate and lower bracket are properly aligned and that the flat edge of the lower bracket is facing inboard.
2. Attach the lower bracket to the air springs with the two 3/8”-16x7/8” bolts, lock washers, and flat washers (Figure 5).
3. Tighten the bellows to both brackets to 20 ft. lbs.

IV. Installing the Spring Assembly

1. Set the air spring assembly on the leaf spring over the axle.

NOTE: Some vehicles may require the leaf spring U-bolts to be trimmed to allow the bottom bracket to fit properly (Figure 7).

2. Attach the lower bracket to the leaf spring using provided U-bolts, flat washers and lock nuts as shown in Figure 1.
3. Torque to 20 ft./lbs.

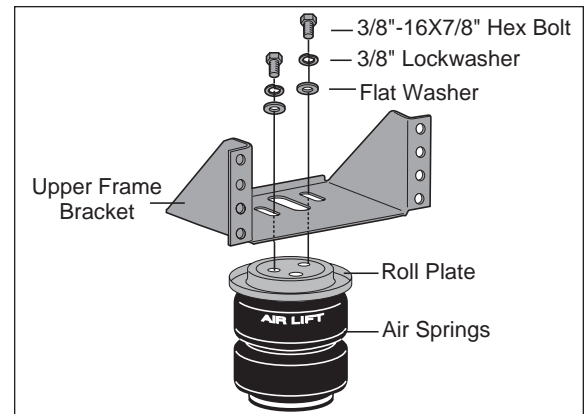

Figure 4

V. Adjusting Your Kit

1. Align the assembly vertically and horizontally (Figure 7). There must be sufficient clearance between the air springs, the frame, and the tire and brake drum at the maximum inflated diameter (7.0"). Tighten the upper bracket and mounting bolts for the bellows to 20 ft./lbs.
2. On some vehicles the outer flange of the axle jounce bumper bracket extends out from the frame rail. Trim the outer flange of the bracket or remove the bracket assembly entirely to provide sufficient clearance from bellows to the frame for the maximum inflated diameter (7.0").

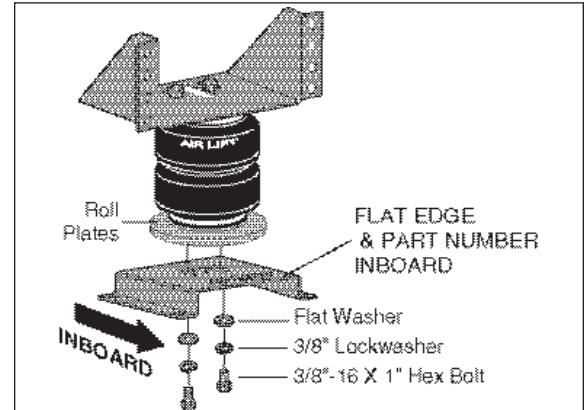

Figure 5

3. Position the upper bracket so that it is parallel with the lower bracket.

NOTE: The kit mounts so that it follows the angle of the leaf springs.

4. Align the assembly vertically and horizontally. The distances between points X and Y (Figures 6 and 7) should be approximately equal, between 5 and 7 at normal ride height.
5. Adjust the upper bracket so that at least four bolt holes (two on each side) will be on a flat section of the frame rail. Use the widest bolt spacing possible. Do not drill on the radiused edges of the frame. Clamp the upper bracket to the frame rail with a C-clamp or welding clamp. Before marking any holes, check the following:

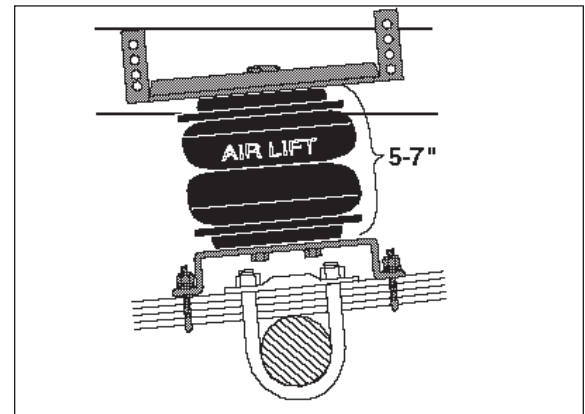

Figure 6

1. Are four holes in the upper bracket positioned on flat section of the frame rail?
2. Are the upper and lower brackets aligned vertically with each other?
3. Are the distances between points X and points Y equal?
4. Is the distance between the upper and lower brackets between 5" and 7"?

Caution - Do not drill holes into the frame until hydraulic lines, gas lines and electrical wires have been moved aside on both sides of the frame.

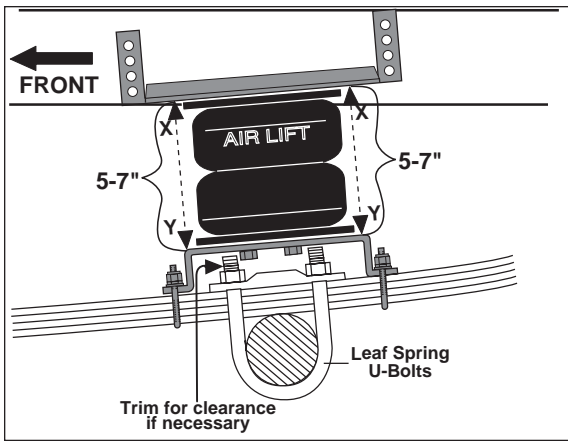

Figure 7

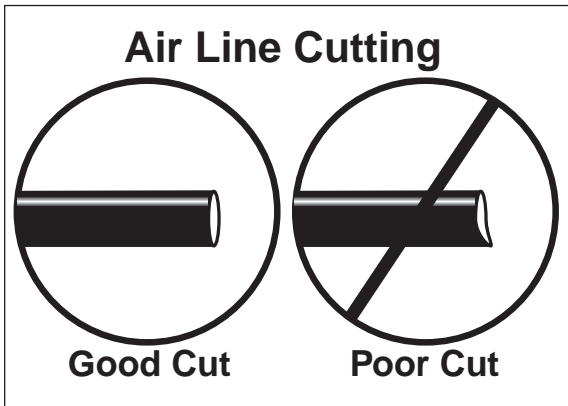

Figure 8

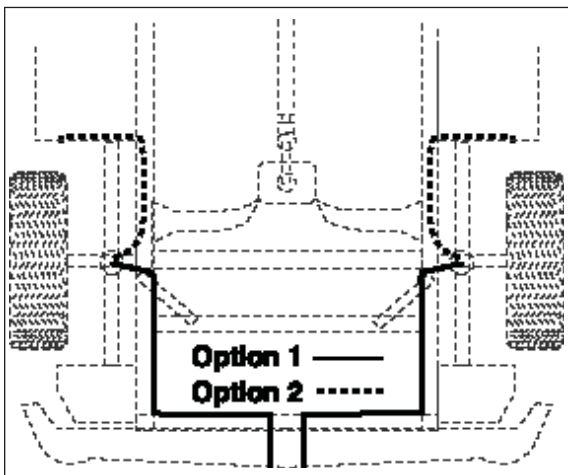

Figure 9

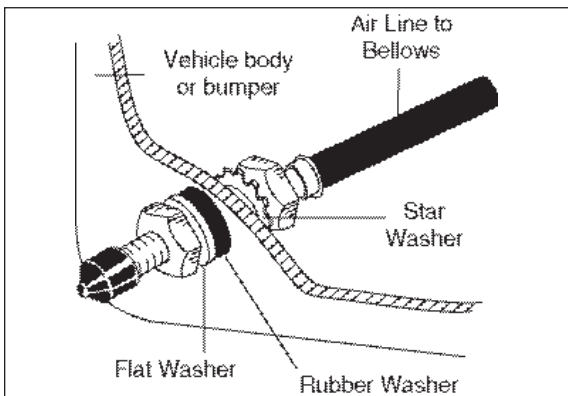

Figure 10

6. Center punch and drill one 3/8" locator hole through the frame at one bolt location and install one 1.5" washerhead frame bolt, over-sized washer, and lock nut.
7. Check the alignment of the upper and lower bracket once again to be sure that the distances between points X and points Y are equal and between 5 and 7 inches. Center punch and drill one more 3/8" hole on the opposite side, install one 1.5" washerhead frame bolt, over-sized washer and lock nut.
8. Remove the clamps and drill the remaining two holes. Install the remaining hardware and tighten all nuts to 20 ft./lbs.
9. Using the slots in the upper bracket, align the air springs both inboard and outboard. Tighten the air springs to the brackets to 20 ft./lbs.
10. Repeat the procedure for the other side of the vehicle.

VI. Installing the Air Lines

IMPORTANT NOTE: When installing the air lines, there must be at least six inches of clearance between the air lines and any heat sources.

1. Insert a length of air line into the open port at the top of the air spring. Use Figure 9 as an air line routing guide.
 2. Choose a convenient location for mounting the inflation valves. Popular locations for the inflation valve are:
The wheel well flanges; The license plate recess in bumper; Under the gas cap access door; Through license plate (Figure #).
- NOTE: Whatever the chosen location is, make sure there is enough clearance around the inflation valves for an air chuck.*
3. Drill a 5/16" hole to install the inflation valves.
 4. Cut the air line assembly (AA) in two equal lengths.

When cutting or trimming the air line, use a hose cutter (Air Lift P/N 10530), a razor blade or a sharp knife. A clean, square cut will ensure against leaks. Do not use wire cutters or scissors to cut the air line. These tools may flatten or crimp the air line causing it to leak around the O-ring seal inside the elbow fitting.

5. Install the inflation valves as shown in Figure 10.
6. Keep at least 6" of clearance between the air line and heat sources, such as the exhaust pipes, muffler, or catalytic converter. Avoid sharp bends and edges. Leave at least 2" of slack when securing the air lines to allow for any movement that might pull on the air line.
7. Cut off air line leaving approximately 12" of extra air line. Insert the air line into the air fitting. Simply push the air line into the 90° swivel fitting until it bottoms out (9/16" of air line should be in the fitting).

VII. Checking for Leaks

1. Inflate the air spring to 30 p.s.i.
2. Spray all connections and the inflation valves with a solution of $\frac{1}{5}$ liquid dish soap and $\frac{4}{5}$ water to check for leaks. You should be able to spot leaks easily by looking for bubbles in the soapy water.
3. After the test, deflate the springs to the minimum pressure required to restore the Normal Ride Height, but not less than 5 p.s.i.
4. **IMPORTANT:** Check the air pressure again after 24 hours. A 2 to 4 p.s.i. loss after initial installation is normal.

VIII. Maintenance and Operations

Minimum Air Pressure	Maximum Air Pressure
5 p.s.i.	100 p.s.i.
<i>Failure to maintain correct minimum pressure (or pressure proportional to load), bottoming out, over-extension, or rubbing against another component will void the warranty.</i>	

By following these steps, vehicle owners will obtain the longest life and best results from their air springs.

1. Check the air pressure weekly.
2. Always maintain Ride Height. Never inflate beyond 100 p.s.i.
3. If you develop an air leak in the system, use a soapy water solution to check all air line connections and the inflation valve core before deflating and removing the air spring.
4. When increasing load, always adjust the air pressure to maintain the Normal Ride Height. Increase or decrease pressure from the system as necessary to attain Normal Ride Height for optimal ride and handling. Remember that loads carried behind the axle (including tongue loads) require more leveling force (pressure) than those carried directly over the axle.
5. **IMPORTANT:** For your safety and to prevent possible damage to your vehicle, *do not exceed maximum Gross Vehicle Weight Rating (GVWR), as indicated by the vehicle manufacturer.* Although your air springs are rated at a maximum inflation pressure of 100 p.s.i. The air pressure actually needed is dependant on your load and GVWR, which may be less than 100 p.s.i. Check your vehicle owners manual and do not exceed the maximum load listed for your vehicle.
6. Always add air to springs in small quantities, checking the pressure frequently. Sleeves require less air volume than a tire and inflate quickly.
7. *Should it become necessary to raise the vehicle by the frame, make sure the system is at minimum pressure (10 p.s.i.) to reduce the tension on the suspension/brake components. Use of on-board leveling systems do not require deflation or disconnection.*



Thank you for purchasing Air Lift Products

Mailing Address:
AIR LIFT COMPANY
P.O. Box 80167
Lansing, MI 48908-0167

Street Address:
AIR LIFT COMPANY
2727 Snow Rd.
Lansing, MI 48917

Local Phone: (517) 322-2144
Fax: (517) 322-0240

For Technical Assistance call 1-800-248-0892

"The Choice of the Professional Installer"

Printed in the USA



Product Use Information

Frequently asked questions

Q. Will installing air springs increase the weight ratings of a vehicle?

No. Adding air springs will not change the weight ratings (GAWR, GCWR and/or GVWR) of a vehicle. Exceeding the GVWR is dangerous and voids the Air Lift warranty.

Q. Is it necessary to keep air in the air springs at all time and how much pressure will they need?

The minimum air pressure should be maintained at all times. The minimum air pressure keeps the air spring in shape, ensuring that it will move throughout its travel without rubbing or wearing on itself.

Q. Is it necessary to add a compressor system to the air springs?

No. Air pressure can be adjusted with any type of compressor as long as it can produce sufficient pressure to service the springs. Even a bicycle tire pump can be used, but it's a lot of work.

Q. How long should air springs last?

If the air springs are properly installed and maintained they can last indefinitely.

Q. Will raising the vehicle on a hoist for service work damage the air springs?

No. The vehicle can be lifted on a hoist for short-term service work such as tire rotation or oil changes. However, if the vehicle will be on the hoist for a prolonged period of time, support the axle with jack stands in order to take the tension off of the air springs.

Tuning the air pressure

Pressure determination comes down to three things — level vehicle, ride comfort, and stability.

1. Level vehicle

If the vehicle's headlights are shining into the trees or the vehicle is leaning to one side, then it is not level (fig. 1). Raise the air pressure to correct either of these problems and level the vehicle.

2. Ride comfort

If the vehicle has a rough and harsh ride it may be due to either too much pressure or not enough (fig. 2). Try different pressures to determine the best ride comfort.

3. Stability

Stability translates into safety and should be the priority, meaning the driver may need to sacrifice a perfectly level and comfortable ride. Stability issues include roll control, bounce, dive during braking and sponginess (fig. 3). Tuning out these problems usually requires an increase in pressure.

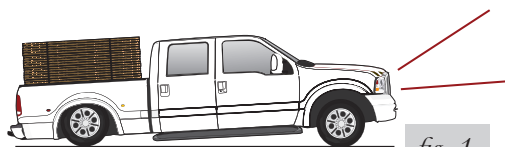

Bad headlight aim

fig. 1



Sway and body roll

fig. 2



Rough ride

fig. 3

Guidelines for adding air:

1. Start with the vehicle level or slightly above.
2. When in doubt, always add air.
3. For motorhomes, start with 50-100 PSI in the rear because it can be safely assumed that it is heavily loaded.
4. If the front of the vehicle dives while braking, increase the pressure in the front air bags, if equipped.
5. If it is ever suspected that the air bags have bottomed out, increase the pressure (fig. 4).
6. Adjust the pressure up and down to find the best ride.
7. If the vehicle rocks and rolls, adjust the air pressure to reduce movement.
8. It may be necessary to maintain different pressures on each side of the vehicle. Loads such as water, fuel, and appliances will cause the vehicle to be heavier on one side (fig. 5). As much as a 50 PSI difference is not uncommon.

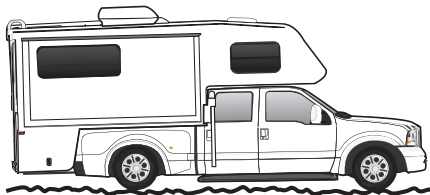

Bottoming out

fig. 4

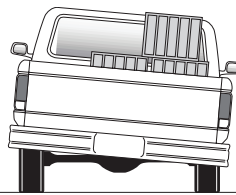

Unlevel

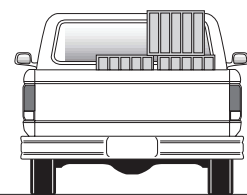

Level

fig. 5

Warranty and Returns Policy

Air Lift Company warrants its products, for the time periods listed below, to the original retail purchaser against manufacturing defects when used on catalog-listed applications on cars, vans, light trucks and motorhomes under normal operating conditions for as long as Air Lift manufactures the product. The warranty does not apply to products that have been improperly applied, improperly installed, used in racing or off-road applications, used for commercial purposes, or which have not been maintained in accordance with installation instructions furnished with all products. The consumer will be responsible for removing (labor charges) the defective product from the vehicle and returning it, transportation costs prepaid, to the dealer from which it was purchased or to Air Lift Company for verification.

Air Lift will repair or replace, at its option, defective products or components. A minimum \$10.00 shipping and handling charge will apply to all warranty claims. Before returning any defective product, you must call Air Lift at (800) 248-0892 in the U.S. and Canada (elsewhere, (517) 322-2144) for a Returned Materials Authorization (RMA) number. Returns to Air Lift can be sent to: Air Lift Company • 2727 Snow Road • Lansing, MI • 48917.

Product failures resulting from abnormal use or misuse are excluded from this warranty. The loss of use of the product, loss of time, inconvenience, commercial loss or consequential damages is not covered. The consumer is responsible for installation/reinstallation (labor charges) of the product. Air Lift Company reserves the right to change the design of any product without assuming any obligation to modify any product previously manufactured.

This warranty gives you specific legal rights and you may also have other rights that vary from state-to-state. Some states do not allow limitations on how long an implied warranty lasts or allow the exclusion or limitation of incidental or consequential damages. The above limitation or exclusion may not apply to you. There are no warranties, expressed or implied including any implied warranties of merchantability and fitness, which extend beyond this warranty period. There are no warranties that extend beyond the description on the face hereof. Seller disclaims the implied warranty of merchantability. (Dated proof of purchase required.)

Air Lift 1000 Lifetime Limited
RideControl Lifetime Limited
SlamAir Lifetime Limited
LoadLifter 5000* Lifetime Limited
EasyStreet Systems 1 Year Limited

Load Controller (I) 2 Year Limited
Load Controller (II) 2 Year Limited
SmartAir 2 Year Limited
Wireless AIR..... 2 Year Limited
Other Accessories..... 2 Year Limited

**formerly SuperDuty*

Thank you for purchasing Air Lift products! For technical support, please call (800) 248-0892.
 Air Lift Company • P.O. Box 80167, MI 48908-0167 • (517) 322-2144 • Fax: (517) 322-0240 • www.airliftcompany.com