



## INSTALLATION INSTRUCTIONS

### 1997-1999 DODGE DAKOTA

**2" KIT # 682 (2WD), 692 (4WD)**

**3" KIT # 683 (2WD), 693 (4WD)**

#### **⚠ WARNING**

Installation of a Performance Accessories body lift kit will change the vehicle's center of gravity and handling characteristics both on- and off-road. You must drive the vehicle safely! Extreme care must be taken to prevent vehicle rollover or loss of control, which could result in serious injury or death. Avoid sudden sharp turns or abrupt maneuvers and always make sure all vehicle occupants have their seat belts fastened.

#### **⚠ WARNING**

Before you install this kit, read and understand all instructions, warnings, cautions, and notes in this instruction sheet and in the vehicle owner's manual.

#### **⚠ CAUTION**

Proper installation of this kit requires knowledge of the factory recommended procedures for removal and installation of original equipment components. We recommend that the factory shop manual and any special tools needed to service your vehicle be on hand during the installation. Installation of this kit without proper knowledge of the factory recommended procedures may affect the performance of these components and the safety of the vehicle. We strongly recommend that a certified mechanic familiar with the installation of similar components install this kit.

#### **⚠ WARNING**

This kit should only be installed on a vehicle that is in good working condition. Before you install the kit, thoroughly inspect the vehicle for corrosion or deformation of the sheet metal around the factory body mounts. If the vehicle is suspected to have been in a collision or misused, do not install this kit. Off-road use of your vehicle with this kit installed may increase the stress applied to the factory body mounts. We do not recommend that any vehicle with a body lift kit installed be involved in any extreme off-road maneuvers such as jumping. Failure to observe this warning may result in serious personal injury and/or severe damage to your vehicle.

#### **⚠ WARNING**

Many states and municipalities have laws restricting bumper heights and vehicle lifts. Consult state and local laws to determine if the changes you intend to make to the vehicle comply with the law. Before combining a body lift with a suspension lift, consult an installation professional to see how this will affect the vehicle.

#### **⚠ WARNING**

The installation of larger tires may reduce the effectiveness of the Braking System.

#### **⚠ WARNING**

Always wear eye protection when operating power tools.

#### **⚠ WARNING**

Before you install this kit, block the vehicle tires to prevent the vehicle from rolling.

#### **⚠ WARNING**

Accidental deployment of the air bag can result in serious personal injury or death. To avoid accidental deployment during installation of the kit, the Supplemental Restraint System (SRS, or airbag) must remain deactivated. Do not allow anyone near the airbag during installation. Refer to the factory service manual or owner's manual for the recommended procedure to disable the SRS. After you install the kit, reactivate the SRS before driving the vehicle.

#### **⚠ NOTE**

Performance Accessories recommends using the Loctite® supplied in the kit on the threads of all kit nuts and bolts unless specified otherwise in these instructions.

# I. Before starting installation

## ⚠ NOTE

You will find it easier to keep track of fasteners if immediately after you remove them you put them in a paper bag and write on the bag which parts they go with.

1. Special tools needed
  - a. Welder or access to a professional welding shop
2. Read all warnings and instructions completely and carefully before you begin.
3. Check to make sure the kit is complete (refer to the Kit Parts List at the end of this document).
4. Only install this kit on the vehicle for which it is intended. During installation, if you encounter something different from what is outlined in the instructions, call technical support at (928) 636-7080.
5. Park vehicle on a clean, dry, flat, level surface and block tires so vehicle cannot roll in either direction.

## A. Engine compartment

1. Battery cables
  - a. Disconnect the negative cable first, then the positive cable from the battery.

## B. Inside cab

1. Airbag fuses

- a. Remove airbag fuses from fuse box. The location of airbag fuses may vary; check the owner's manual.

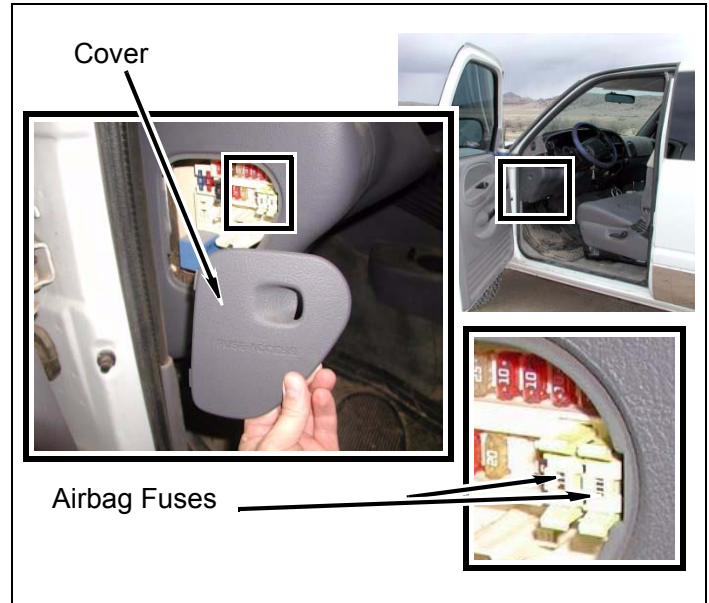

# II. Prepare to install kit

## A. Front of vehicle

1. Front bumper
  - a. Measure and record distance between front bumper and fenders.  
Driver Side \_\_\_\_\_ Passenger Side \_\_\_\_\_
  - b. **Vehicles with fog lights:** Disconnect wire connectors from fog lights.
  - c. Remove four bolts holding bumper to frame. Remove bumper.
  - d. Remove cover from below radiator (attached to bumper and core support).

## B. Engine compartment

1. Fan shroud
  - a. Remove wire loom mounting tabs from bottom of core support. Remove four bolts holding fan shroud to radiator. Allow fan shroud to rest against engine.

## 2. Ground wires

- a. Check routing of ground wire at firewall, near brake booster. If ground wire is routed over brake booster, check to be sure there is ample slack in ground wire. If necessary, reroute ground wire under brake booster.
- b. At driver side frame rail, behind front wheel, loosen bolt holding ground wire to frame. Rotate ground wire to gain slack for lifting cab. Tighten bolt.

## 3. Wire loom

- a. At driver side frame rail, behind front wheel, remove wire loom mounting tab from top of frame.

## 4. Brake lines

- a. Detach brake lines from plastic clips holding lines together. When you lift cab, watch these lines carefully to ensure they are not kinked. It may be necessary to bend lines to gain slack.

## 5. Manual transmission: Clutch fluid line

- a. Check hydraulic clutch fluid line to be sure there is ample slack for lifting. It may be necessary to remove line from mounting clip.

## 6. Automatic transmission: Shift cable

- a. Remove automatic transmission shift cable from clip on driver side inner fender.

## 7. Steering shaft

### ⚠ WARNING

Accidental deployment of the air bag can result in serious personal injury or death. To avoid accidental deployment during installation of the lift kit, the Supplemental Restraint System (SRS, or airbag) must remain deactivated. Do not allow anyone near the airbag during installation. Refer to the factory service manual or owner's manual for the recommended procedure to disable the SRS. After kit installation, the SRS must be reactivated before driving the vehicle.

### ⚠ CAUTION

If the following step is not performed, the airbag clock-spring could be damaged. Do not turn the steering wheel while the steering shaft is disconnected.

- a. Strap steering wheel to prevent accidental movement.

- b. Mark axis of steering shaft U-joint in relation to axis of steering rack (or steering gearbox on 4WD vehicles).

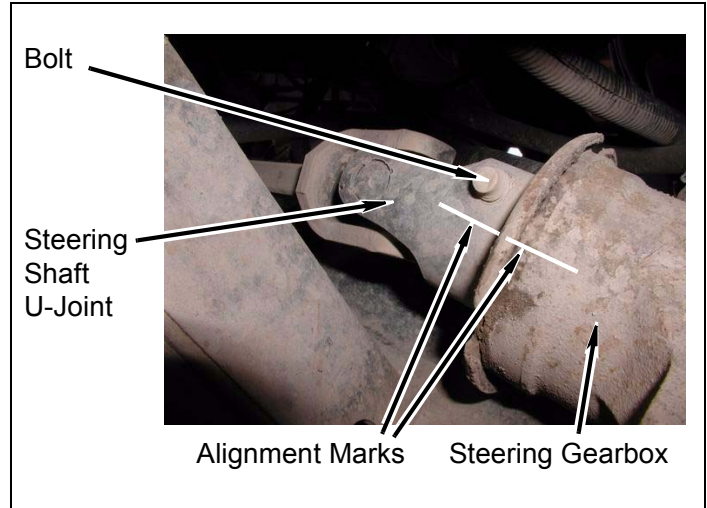

- c. Remove bolt holding steering shaft U-joint to steering rack (steering gearbox on 4WD).
- d. Disconnect steering shaft U-joint from steering rack (steering gearbox on 4WD).

## C. Inside cab

### 1. Shift console

- a. **Manual transmission:** Remove upper portion of transmission shift lever. Remove transmission shift lever boot.
- b. **4WD vehicles:** Remove 4WD shift lever knob and boot.
- c. Remove rubber inserts from cup holders in shift console. Remove three screws holding shift console to floor.
- d. **Vehicles with center storage console:** Remove four screws holding center storage console to floor (they are inside of console).
- e. Gently pull front of shift console upward until clips are released.
- f. Remove screws holding shift console to floor. Remove shift console.
- g. Remove rubber boot from top of transmission.
- h. Push cover down, rotate shift lever to release it, and remove shift lever.

2. **4WD vehicles:** Transfer case shift lever
  - a. Remove four bolts and skid plate from under transmission and transfer case.
  - b. Disconnect transfer case shift linkage rod from transfer case input lever.
  - c. Remove two bolts and transfer case shift lever assembly from side of transmission.

#### D. Fuel filler

1. Fuel filler and vent hoses
  - a. Disconnect fuel filler hose and vent hose from fuel tank. (These are "quick connect" style couplers. Push collar toward tank and pull hose off.)

#### E. Rear of vehicle

1. Spare tire
  - a. Lower spare tire to ground.
  - b. Remove clip holding crank rod to winch mechanism. Remove crank rod.
  - c. Remove plastic collar from crank rod hole in body. The collar will be relocated.

2. Rear bumper
  - a. Measure and record distance between rear bumper and bed/tailgate.  
 Driver Side \_\_\_\_\_ Passenger Side \_\_\_\_\_
  - b. Disconnect wire harnesses from license plate lights.
  - c. Remove six bolts holding rear bumper to frame and remove rear bumper.

### III. Install kit

#### A. Cab

1. Prepare to lift cab from frame.
  - a. Measure and record distance between cab and bed.  
 Driver Side \_\_\_\_\_ Passenger Side \_\_\_\_\_
  - b. Loosen, but DO NOT remove, cab mounting bolts on driver side (three bolts on vehicles with regular cab; four bolts on vehicles with extended or crew cab).

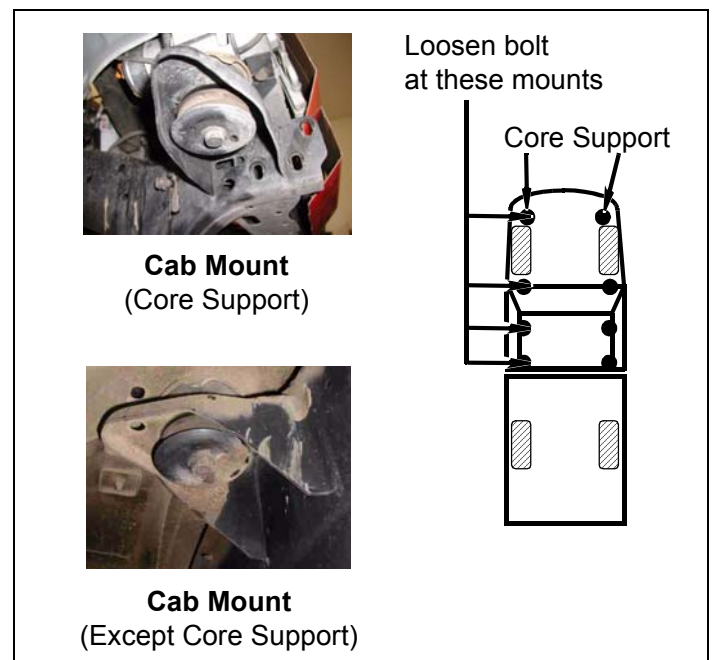

- c. Remove bolt and lower bushing from each cab mount on passenger side.

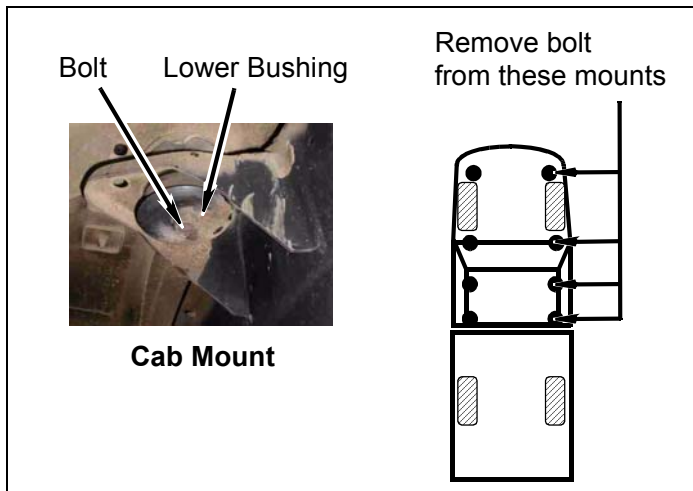

- b. Install a kit **block** on upper bushing at each cab mount:

- **Block**, 2" height x 3" diameter (**2" kit**)
- **Block**, 3" height x 3" diameter (**3" kit**)

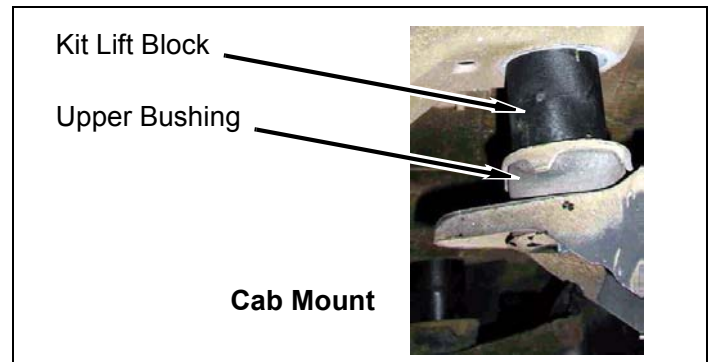

- c. Lower cab onto kit **blocks**.

- d. Install lower bushing and a kit **bolt** on each cab mount. DO NOT tighten:

- **Bolt**, 12mm x 140mm (**2" kit**)
- **Bolt**, 12mm x 160mm (**3" kit**)

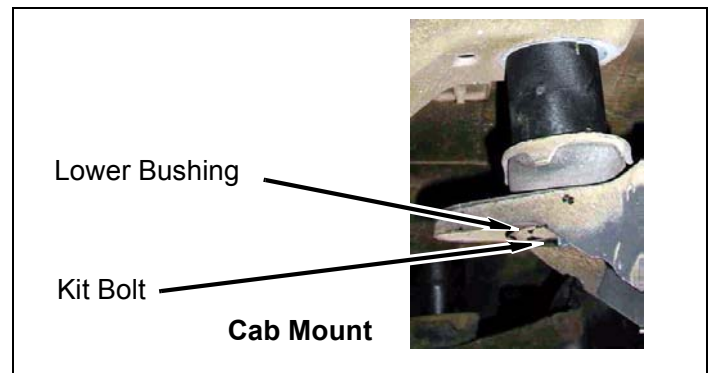

3. Cab driver side

- a. Repeat previous steps on driver side of cab.

4. Finish cab mounting to frame.

- a. Set cab-to-bed spacing according to previous measurement.

**⚠ WARNING**

Use extreme caution when lifting body from frame. To prevent serious personal injury, ensure the lifting device is securely placed. Keep your hands out from between the body and frame.

**⚠ CAUTION**

To prevent damage to the vehicle while lifting the cab, continually check hoses, wires, brake lines, etc. to ensure everything is flexing properly and not binding. Ensure clearance between bed and cab is maintained.

2. Cab passenger side

- a. Using a hydraulic jack and a wooden block, slowly lift passenger side of cab just enough to position a kit **block** between cab mount upper bushing and cab.

**⚠ WARNING**

The kit **lift blocks** must be installed in addition to the factory upper and lower bushings. Installing the kit **lift blocks** without the factory upper and lower bushings could result in damage to the vehicle or serious personal injury.

- b. Remove each kit **bolt**, one at a time, and apply a few drops of Loctite® to threads. Install kit **bolt** with kit **washer** (1/2" SAE). Tighten kit **bolt** to 55 ft. lbs.

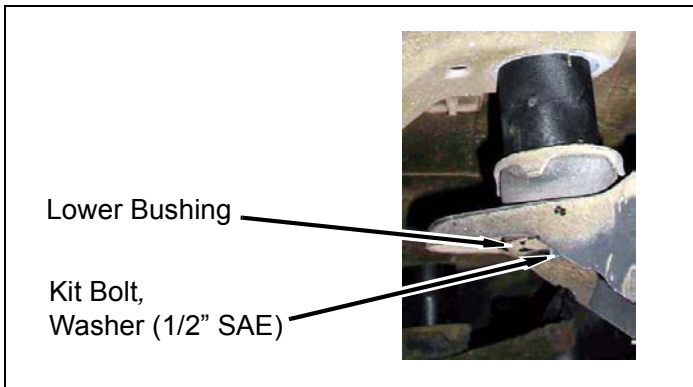

**⚠ WARNING**  
Use extreme caution when lifting the bed from the frame. To prevent serious personal injury, ensure the lifting device is securely placed. Keep your hands out from between the bed and frame.

**⚠ CAUTION**  
To prevent damage to the vehicle while lifting the bed, continually check hoses, wires, brake lines, etc. to ensure everything is flexing properly and not binding. Ensure clearance between bed and cab is maintained.

## B. Bed

1. Prepare to lift bed from frame.

- a. Loosen, but DO NOT remove, bed mounting bolts on driver side (three bolts on vehicles with short bed; four bolts on vehicles with long bed).

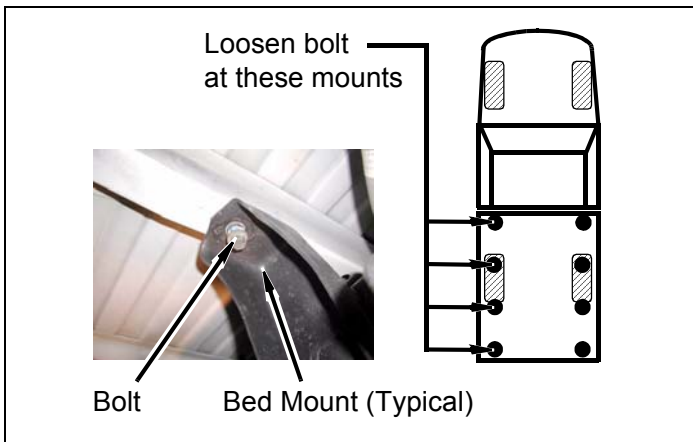

- b. Remove bolt from each bed mount on passenger side.

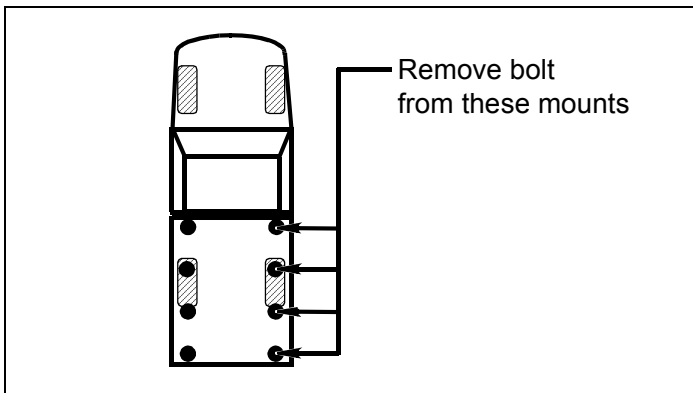

2. Bed passenger side

- a. Using a hydraulic jack and a wooden block, slowly lift passenger side of bed just enough to position a kit **block** between bed mount (frame) and bed.

- b. Install a kit **block** on the frame at mount closest to rear end of bed:

- **Block**, 2" height x 2" diameter (**2" kit**)
- **Block**, 3" height x 2" diameter (**3" kit**)

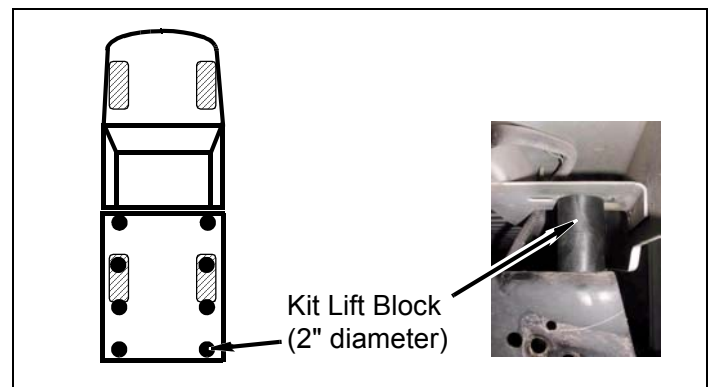

- c. Install a kit **block** at other mounts:

- **Block**, 2" height x 3" diameter (**2" kit**)
- **Block**, 3" height x 3" diameter (**3" kit**)

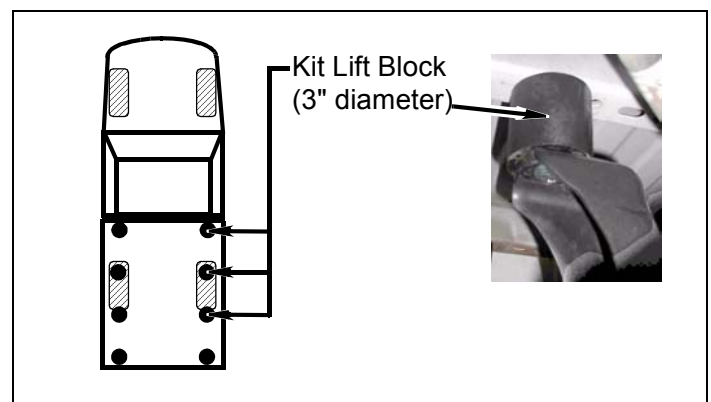

- d. Lower bed onto kit **lift blocks**.

- e. Insert a kit **bolt** through kit **washers** (3/8" USS and 7/16" USS), then install kit **bolt** at each bed mount, . DO NOT tighten.

- **Bolt**, 10mm x 80mm (**2" kit**)
- **Bolt**, 10mm x 100mm (**3" kit**)

3. Bed driver side

- a. Repeat previous steps on driver side of bed.

4. Finish bed mounting to frame

- a. Set cab-to-bed spacing according to previous measurement.
- b. Remove each kit **bolt**, one at a time, and apply a few drops of Loctite® to threads. Install kit **bolt** with kit **washers**. Tighten kit **bolt** to 40 ft. lbs

**C. Rear of vehicle**

1. Spare tire

- a. Remove license plate frame.
- b. Measure down 2" (**2" kit**) or 3" (**3" kit**) from spare tire crank rod hole. Using a hole saw, cut a new hole.
- c. Install plastic collar (from original crank rod hole) in new hole. It may be necessary to glue plastic collar in place.
- d. Install crank rod through new hole and engage end of it onto winch mechanism. Secure crank rod to winch mechanism with original clip.
- e. Raise spare tire to stowed position (all the way up).
- f. Install license plate frame.

2. Rear bumper

<p><b>⚠WARNING</b></p> <p>The following procedure for raising the rear bumper is intended to enhance the appearance of the vehicle only. The rear bumper will no longer be rated for towing of any kind. Any attempt to tow with the rear bumper after it has been lifted can result in damage to the vehicle and possible personal injury. Any towing that is done after the bumper has been lifted should only be done with a rated class III receiver type hitch. If you wish to tow with the bumper after the body lift kit has been installed, reinstall the rear bumper in its original location using the original hardware.</p>
---

<p><b>⚠NOTE</b></p> <p>To raise the rear bumper, new mounting holes must be drilled in the frame (and in the original bumper brackets on a <b>3" kit</b>).</p>
--

- a. Drill 1/2" holes in frame as shown below.

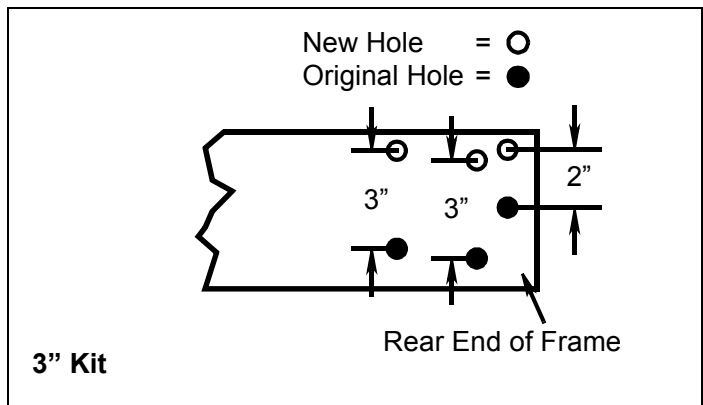
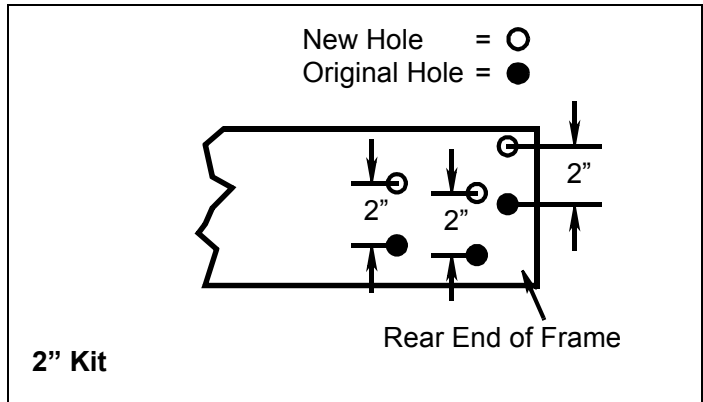

- b. **3" kit:** Locate hole in rear bumper bracket that corresponds to rear hole in frame. Measure down 1" and drill a 1/2" hole in rear bumper bracket at that location.

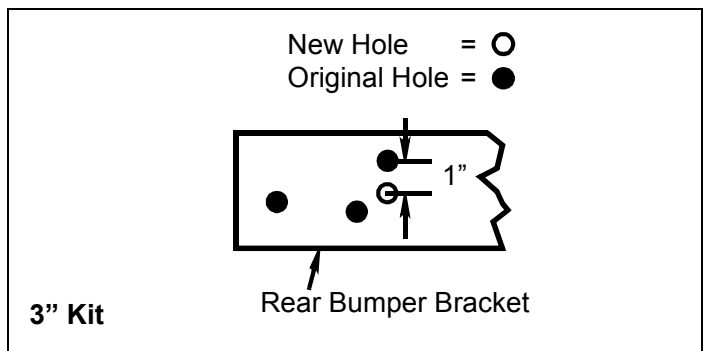

- c. **All kits:** Set rear bumper into position.
- d. Insert a kit **bolt** (7/16" x 1 1/2") through a kit **washer** (7/16" USS), then install kit **bolt** through rearmost hole from inside of frame.

- e. Install a kit **washer** (7/16" USS) and kit **nut** (7/16" nylock) on kit **bolt**.
- f. Apply Loctite® to threads of bolts that originally held bumper to frame. Install original bolts in forward two holes from inside of frame. Install original nuts.
- g. Adjust bumper to bed/tailgate clearance, then tighten all bumper mounting bolts.
- h. Connect wire connectors to license plate lights.

## D. Fuel filler

- 1. Fuel filler and vent hoses
  - a. Connect fuel filler hose and vent hose to fuel tank. (Ensure "quick connect" couplers lock into place. It may seem like hoses are being stretched, but there is enough slack.)

## E. Engine compartment

- 1. Steering shaft
  - a. Install kit **steering extension** on input shaft of steering rack (steering gearbox on 4WD vehicles). It should only go on one way.
  - b. Install (DO NOT tighten) kit **bolt** (3/8" x 1 1/4", socket head) in kit **steering extension**. Be sure kit **bolt** crosses recessed area of input shaft. This will prevent separation of kit **steering extension** from input shaft.
  - c. Try to pull kit **steering extension** off of input shaft. If kit **steering extension** comes off, it has not been installed correctly. Reinstall it.
  - d. Install steering shaft on kit **steering extension**.
  - e. Install original bolt in steering shaft. Be sure original bolt crosses recessed area of kit **steering extension**. This will prevent separation of steering shaft from kit **steering extension**.
  - f. Try to pull steering shaft off of kit **steering extension**. If kit **steering extension** comes off, it has not been installed correctly. Reinstall it.
  - g. Apply Loctite® to threads of kit **bolt** and original bolt, then tighten to 33 ft. lbs.

## F. Inside cab

- 1. **Manual transmission:** Shift lever
  - a. Place bottom portion of shift lever in a vise. Heat shift lever at the bend, then bend it forward about 1/2".
  - b. Install bottom portion of shift lever into transmission. Turn cover and lock it into place.
  - c. Install upper portion of shift lever in lower portion of shift lever. Be sure boot is in place. Tighten securely. Install plastic cover.
  - d. Check operation of shift lever. Be sure transmission engages fully in all gears.

## G. Engine compartment

- 1. **Automatic transmission:** Shift cable
  - a. Be sure shift cable is not interfering with anything in engine compartment. No further modifications should be required.

## H. Bench work

**NOTE**  
A certified welder should perform all welding.

- 1. **4WD vehicles:** Transfer case shift lever
  - a. Remove plastic insert from shift lever positioning bracket.
  - b. Scribe a line along axis of shift lever, between top of positioning bracket and the bend in shift lever.

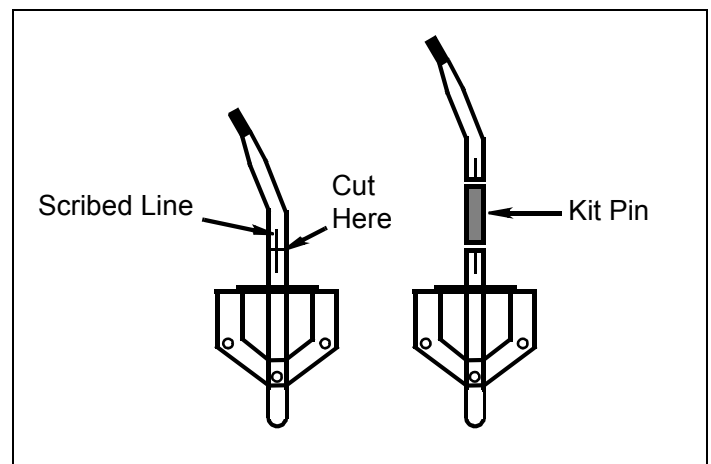



- c. Cut shift lever into two pieces in middle of line.
- d. To prevent heat damage while welding, insulate rest of shift mechanism.
- e. Align two halves of scribed lines, then weld kit **pin** between two parts of shift lever:
  - Pin, 1/2" x 2" (**2" kit**)
  - Pin, 1/2" x 3" (**3" kit**)
- f. After welds cool, install plastic insert.
- g. Place shift lever in a vise. Heat and bend shift lever back about 1/4" This will help the transfer case engage in 2H.

## I. Underside of vehicle

1. **4WD vehicles:** Transfer case shift lever assembly
  - a. Install shift lever assembly on side of transmission using original bolts.
  - b. Connect linkage rod to transfer case. Tighten nut.
  - c. Install boot over shift lever. Because shift lever has been lengthened, the throw is now longer. It may be necessary to glue boot into place in order to keep it from moving around.
  - d. Shift transfer case into 4L. If shift lever is hitting plastic console, loosen adjusting nut on transfer case linkage rod. Adjust linkage so lever can be placed securely in 4L, but will not be too far forward to stay in 2H. Tighten adjusting bolt.
  - e. Install shift knob, mounting screw, and cap.
  - f. Install skid plate under vehicle.

## J. Engine compartment

1. Brake lines
  - a. At driver side inner fender, check brake lines that you removed from clips. If necessary, bend lines to gain more slack. Be extremely careful not to kink lines.
2. Positive battery cable

- a. If positive battery cable will not reach battery, disconnect cable mounting bracket at frame. Use a kit cable tie to secure battery cable to power steering hose.

### 3. Automatic transmission: Fan shroud

- a. Cut lower mounting tab off of passenger side of fan shroud. Be careful not to damage hoses or lines nearby.

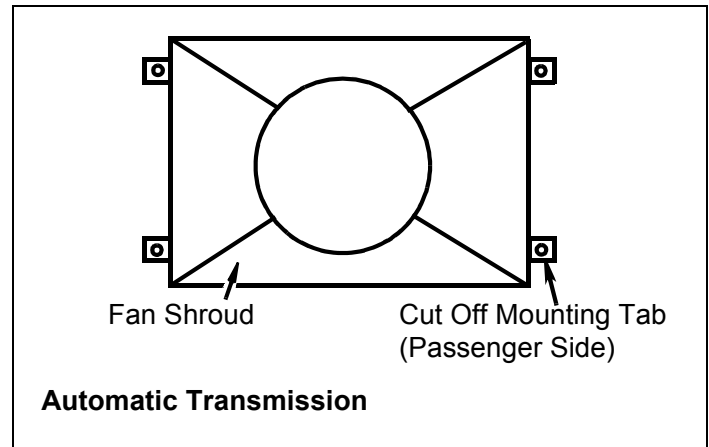

- b. Using three bolts that originally held fan shroud to radiator, install three kit **brackets** ("L"-shaped) on radiator in all locations except lower passenger side (where you removed mounting tab).
- c. Install fan shroud on studs of kit **brackets**. Install a kit **washer** (1/4" SAE) and kit **nut** (1/4" nylock) on each stud.
- d. Check fan to fan shroud clearance. Tighten fan shroud fasteners.
- e. Using remaining bolt that originally held fan shroud to radiator, install kit **bracket** ("L" shaped) on lower passenger side of radiator. Using hole in kit **bracket** ("L" shaped) as a template, mark fan shroud. Remove kit **bracket** ("L" shaped). Using a 1/4" drill, drill a hole in fan shroud where marked.

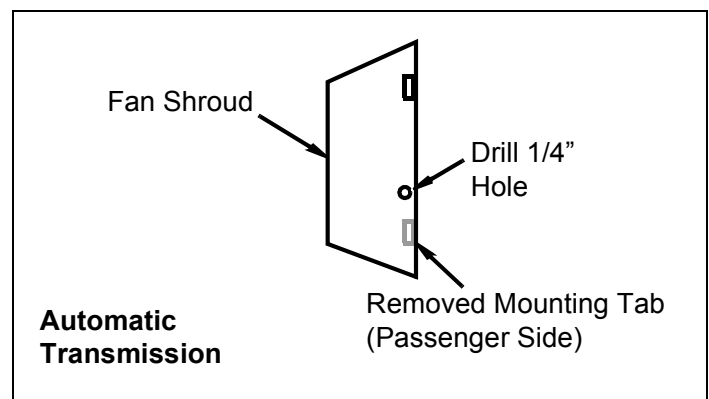

- f. Install kit **bracket** (“L”-shaped) on radiator. Insert a kit **bolt** (1/4” x 1”) through a kit **washer** (1/4” SAE). From inside of fan shroud, insert kit **bolt** (1/4” x 1”) through 1/4” hole you drilled, a kit **washer** (1/4” SAE), and kit **bracket** (“L”-shaped). Install a kit **nut** (1/4” nylock) on kit **bolt** (1/4” x 1”).
- g. Check fan to fan shroud clearance. Tighten fan shroud fasteners.
- h. Drill a 1/4” hole in bottom center of fan shroud (to install kit **wire loom**). Secure wire harness to bottom of fan shroud with a kit **wire loom**, a kit **bolt** (1/4” x 1”), kit **washers** (1/4” SAE), and a kit **nut** (1/4” nylock).
- i. Use kit **zip ties** to secure wire harness to outside edges of fan shroud (possibly to core support). Be sure that wire harness cannot contact fan or any other moving parts.

- c. Install kit **bracket** (front bumper outer) behind two pieces of outer support bracket. Install a kit **bolt** (7/16” x 1”) in top hole of kit **bracket** and top slot in original bumper mounted plate.

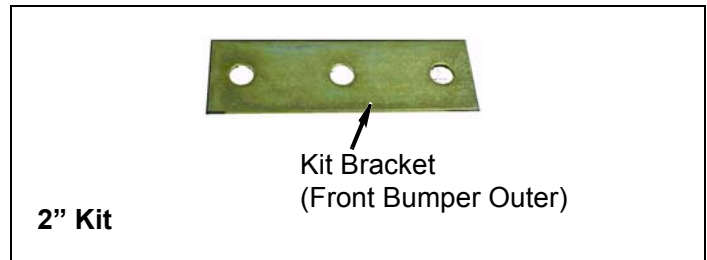

- d. Install original bolts in bottom two holes in kit **bracket** (front bumper outer), then in original holes in bottom portion of original bracket. The top original bolts should go into bottom slot on top bracket. Install nuts on original bolts. Snug all bolts, but do not tighten. The brackets will need to be adjusted after bumper has been installed.

- e. Install assembly on bumper using original torx screws. Tighten torx screws securely.

- f. Install bumper on kit **brackets** (front bumper inner) using four kit **bolts** (7/16” x 1 1/2”), eight kit **washers** (7/16” USS), and four kit **nuts** (7/16” nylock). Do not tighten.

- g. Using original bolts, install outer support brackets on frame.

- h. Adjust clearance between bumper and fenders as recorded earlier.

- i. Tighten bolts: Remove each bumper bolt one at a time, apply Loctite® to threads, install, and tighten.

- j. Connect any wire harnesses that were disconnected.

## 2. 3” kit: Front bumper

- a. Using original front bumper mounting hardware, install kit **brackets** (front bumper inner) on inside mounts. The “C” of kit **bracket** should be open to rear of vehicle. Center the kit **brackets** on each mount. Apply Loctite® to bolt threads. Tighten bolts.

- b. Remove outer support brackets from front bumper. (On each side of vehicle, two Torx head screws fasten brackets to bumper.) Separate two pieces of outer support brackets.

## 4. Manual transmission: Fan shroud

- a. Install four kit **brackets** (“L”-shaped) on radiator using four bolts that originally held fan shroud to radiator.
- b. Install fan shroud on studs of kit **brackets**. Install a kit **washer** (1/4” SAE) and kit **nut** (1/4” nylock) on each stud.
- c. Check fan to fan shroud clearance. Tighten fan shroud fasteners.

## K. Front of vehicle

### 1. 2” kit: Front bumper

- a. Using original front bumper mounting hardware, install kit **brackets** (front bumper inner) on inside mounts. The “C” of kit **bracket** should be open to rear of vehicle. Center the kit **brackets** on each mount. Apply Loctite® to bolt threads. Tighten bolts.
- b. Remove outer support brackets from front bumper. (On each side of vehicle, two Torx head screws fasten brackets to bumper.) Separate two pieces of outer support brackets.

- c. Locate slot in plate that attaches to bumper. Drill a 1/2" hole about 11/16" below this slot.
- d. Install kit **bracket** (front bumper outer) behind two pieces of outer support bracket. Install a kit **bolt** (7/16" x 1") in top hole of kit **bracket** and top slot in original bumper mounted plate.

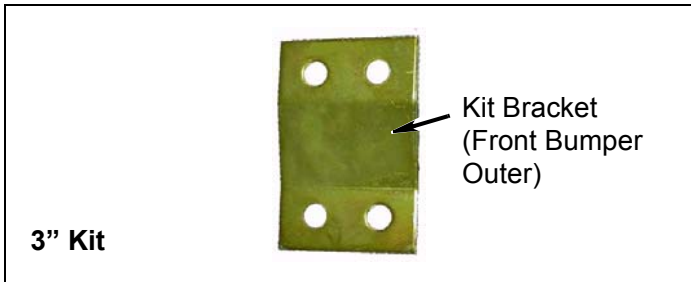

- e. Install original bolts in bottom two holes in kit **bracket** (front bumper outer), then in original holes in bottom portion of original bracket. The top original bolts should go into new hole in top bracket. Install nut on bottom bolt.
- f. Grind washer on remaining nut flat so it can clear edge of top bracket.
- g. Snug all bolts, but do not tighten. The brackets will need to be adjusted after bumper has been installed. Install assembly on bumper using original Torx screws.
- h. Install bumper on kit **brackets** (front bumper inner) using four kit **bolts** (7/16" x 1 1/2"), eight kit **washers** (7/16" USS), and four kit **nuts** (7/16" nylock). Do not tighten.
- i. Using original bolts, install outer support brackets on frame.
- j. Adjust clearance between bumper and fenders as recorded earlier.
- k. Remove each bumper bolt one at a time, apply Loctite® to threads, install, and tighten.
- l. Connect any wire harnesses that were disconnected.

#### L. Crush blocks (bed spacers)

- 1. Set four kit **crush blocks** (bed spacers) in place on frame below bed cross-channels.

- 2. Weld kit **crush blocks** to frame.

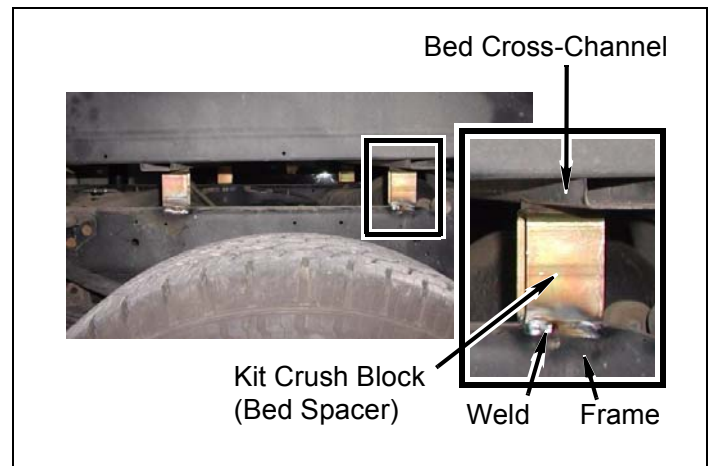

## IV. After completing installation

### A. Inside cab

- 1. Airbag fuses
  - a. Install airbag fuses in fuse box. The location of airbag fuses may vary; check the owner's manual.

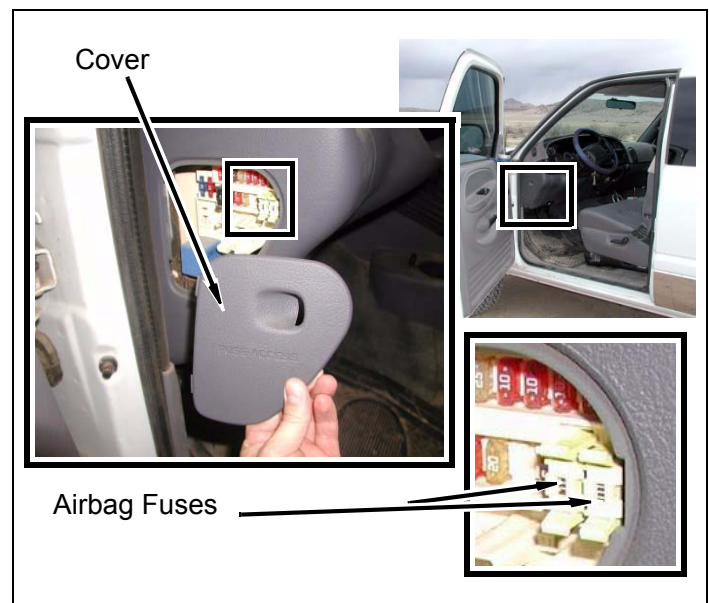

### B. Engine compartment

- 1. Battery cables
  - a. Connect both battery cables. Be sure to connect the positive cable first, then the negative cable.

### C. Warning label

1. Install kit **label** (warning) on vehicle dash in plain sight of all vehicle occupants.

### D. Vehicle check

1. Check all hoses, cables, wires, a/c lines, trans cooler lines, etc. to be sure there is ample slack.
2. Check clearance between fan and fan shroud. Be sure fan does not contact fan shroud. Check hydraulic clutch line. Be sure there is ample slack in line. Check clutch operation.
3. Start vehicle. Check all vehicle systems for proper operation. Test drive in all gears and 4WD ranges. Ensure the transfer case shift lever will stay in gear. It may require further adjustment.
4. Double check all fasteners in 500 miles and as part of your regular maintenance schedule.

Rev. 02 Copyright 05/04 Performance Accessories

## Kit Parts List

### Qty.    Description

#### Kits 682/692

2	<b>Block</b> , lift, 2" height x 2" diameter
12	<b>Block</b> , lift, 2" height x 3" diameter
8	<b>Bolt</b> , 10mm x 80mm
6	<b>Bolt</b> , 12mm x 140mm
1	<b>Pin</b> , 4WD shift lever extension (1/2" x 2")

#### Kits 683/693

2	<b>Block</b> , lift, 3" height x 2" diameter
12	<b>Block</b> , lift, 3" height x 3" diameter
8	<b>Bolt</b> , 10mm x 100mm
6	<b>Bolt</b> , 12mm x 160mm
1	<b>Pin</b> , 4WD shift lever extension (1/2" x 3")

#### All kits

4	<b>Block</b> , crush (bed spacer), metal
2	<b>Bolt</b> , 1/4" x 1"
1	<b>Bolt</b> , 3/8" x 1 1/4", socket head
2	<b>Bolt</b> , 7/16" x 1"
6	<b>Bolt</b> , 7/16" x 1 1/2"
1	<b>Bracket</b> , fan shroud-to-radiator ("L"-shaped) <sup>(1)</sup>
4	<b>Bracket</b> , fan shroud-to-radiator (studded)
2	<b>Bracket</b> , front bumper inner
2	<b>Bracket</b> , front bumper outer
1	<b>Bracket</b> , wire loom
1	<b>Label</b> , logo
1	<b>Label</b> , warning
1	<b>Loctite</b> ®, 6ml tube
5	<b>Nut</b> , 1/4" nylock
8	<b>Nut</b> , 7/16" nylock
1	<b>Steering extension</b>
7	<b>Washer</b> , 1/4" SAE
8	<b>Washer</b> , 3/8" USS
4	<b>Washer</b> , 7/16" SAE
20	<b>Washer</b> , 7/16" USS
6	<b>Washer</b> , 1/2" SAE
3	<b>Zip tie</b>

---

(1) - Required for automatic transmission only.